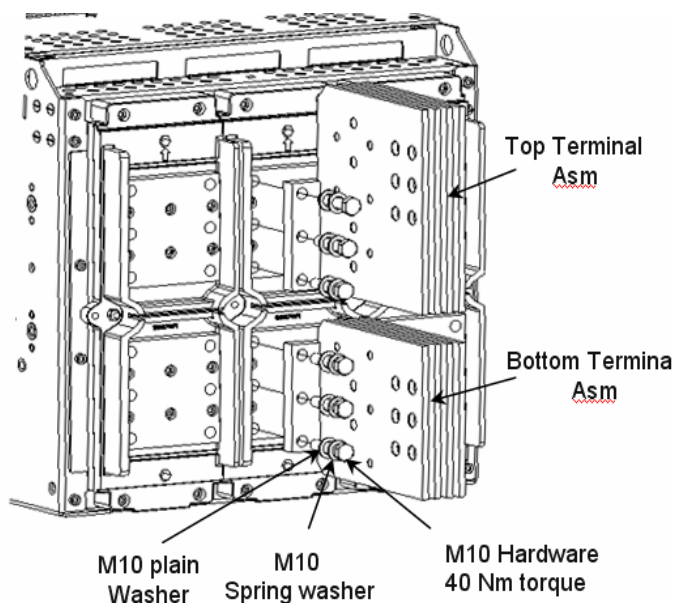


*DEH-41434 Installation Instructions*

## EntelliGuard® G Circuit Breaker Accessories Back Connected Terminations for Cassette

### Back Connected Terminations Cassette Envelope 2 – 3200A ANSI

Terminal assemblies are supplied with the EntelliGuard breaker.



**Fig A. Back Connected Terminations, (Middle pole) for 3200 Amperes (ANSI) 3 pole**

**Table 1. Back Connected Terminations  
Catalog numbers**

Envelope Size	Catalog #	Description	TYPE
Envelope 2	GBB232TBC3	Top side	3 pole
	GBB232BBC3	Bottom side	3 pole
	GBB232TBC4	Top side	4 pole
	GBB232BBC4	Bottom side	4 pole



**WARNING:** Before installing any accessories, turn the breaker OFF, disconnect it from all voltage sources, and discharge the closing springs.



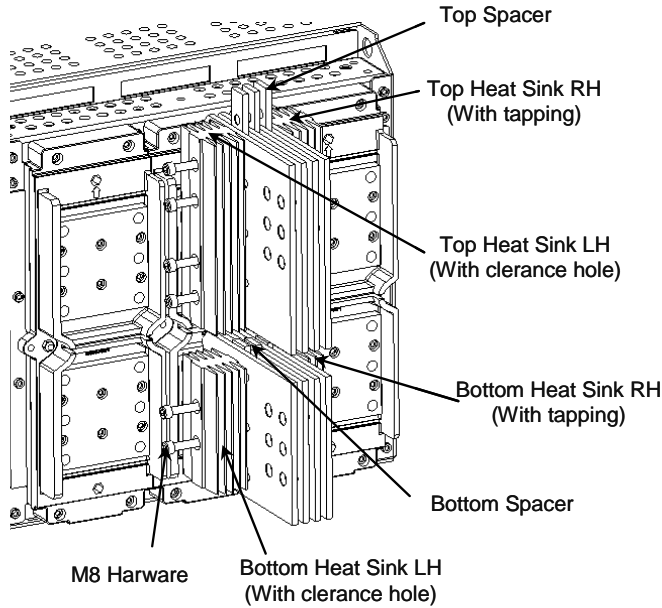
**AVERTISSEMENT:** Avant d'installer tout accessoire, mettre le disjoncteur en position OFF, le déconnecter de toute tension d'alimentation, et décharger les ressorts d'armement

### **Back Connected Terminations Assembly (3 Pole) Procedure:**

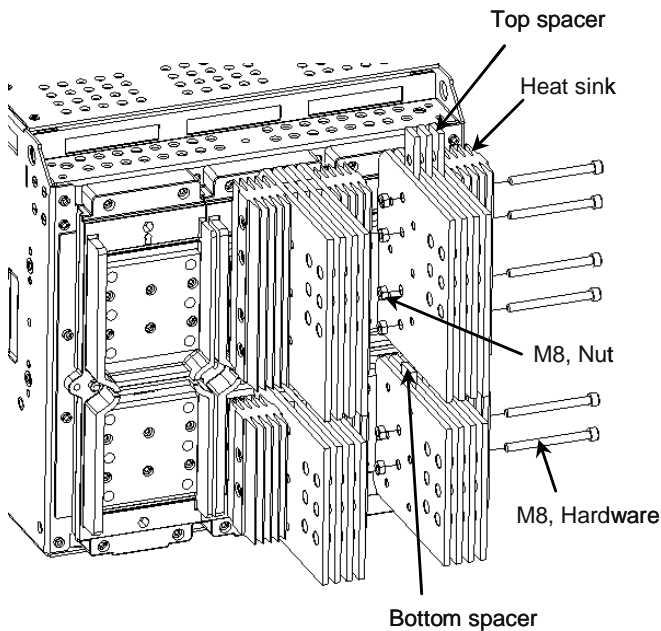
1. Turn the breaker off and discharge the closing springs by depressing the OFF and ON buttons in the sequence OFF-ON-OFF. Verify that the breaker OFF-ON indicator shows OFF on a green background and that the charge indicator shows DISCHARGE on a white background. If installing in a draw-out type breaker remove breaker from cassette before continuing.
2. Assemble the middle bottom and top Back Connected Termination assemblies first to the cassette back terminal support as shown in Fig A.
3. Middle Terminal assemblies to be tightened with M10 hardware's as shown in Fig A, to 40 Nm (29.5 ft-lbs) torque.
4. Assemble the heat sinks LH & RH with spacers introduced in between the multiple pads of terminal assemblies as shown in Fig B for bottom & top sides. Tightened them with M8 mounting hardware's to 16 Nm (11.8 ft-lbs) torque.
5. Assemble the outer terminal assemblies on bottom and top side with M10 hardware tightened to 40 Nm (29.5 ft-lbs) torque as shown in Fig C.
6. Assemble the heat sinks RH with clearance holes & spacers introduced in between the multiple pads of outer terminal assemblies as shown in fig D, for bottom & top sides and tightened them

with M8 mounting hardware's to 16 Nm (11.8 ft-lbs) torque.

- Assemble remaining terminal assemblies similarly on all poles so as to populate as 3pole / 4 pole breaker.

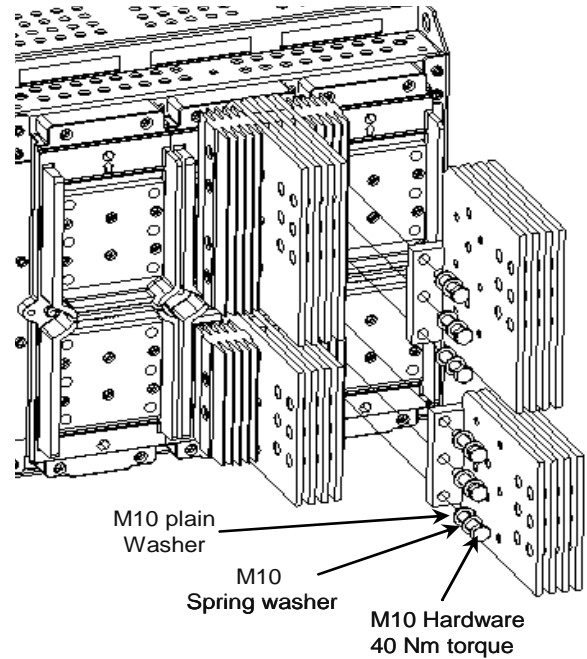


**Fig B. Heat sink Asm with spacers (Middle pole) for 3200 Amperes (ANSI) 3 pole**



**Fig D. Outer pole Heat Sink with spacer assembly for 3200 Amperes (ANSI), 3 Pole**

- The bus bars to be supported within 200mm distance and tightened to 80Nm (59 ft-lbs) torque.



**Fig C. Outer pole Back Connected Terminations assembly for 3200 Amperes (ANSI) 3 Pole**

**\*\* For 3 Pole , L2 Phase to have two heat sinks,  
While outer poles L1 & L3 to have only one outer  
heat sinks assembled**

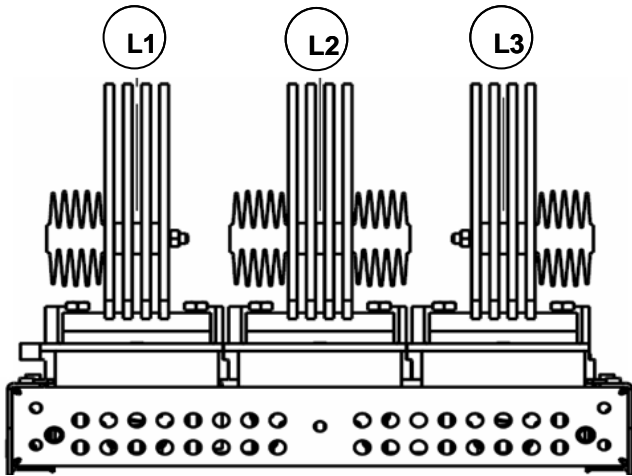


Fig E. Envelope 2, 3200A ANSI 3 Pole Top view

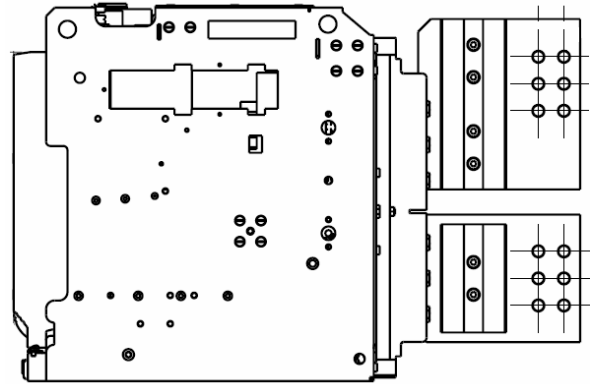


Fig F. Envelope 2 , 3200A ANSI 3 Pole Side view

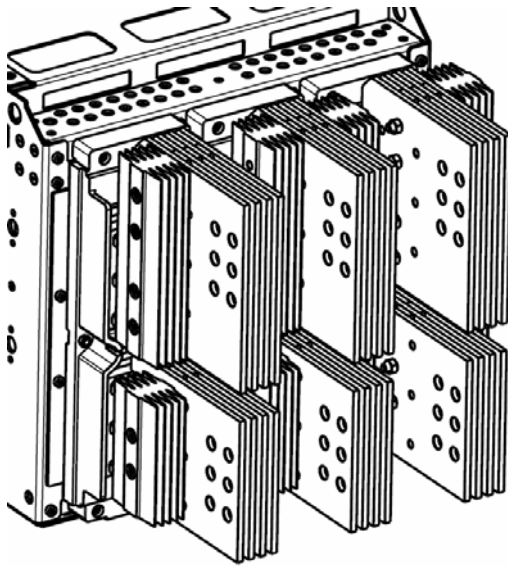
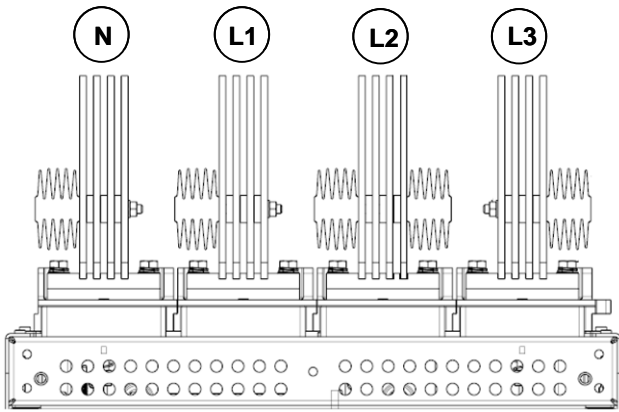


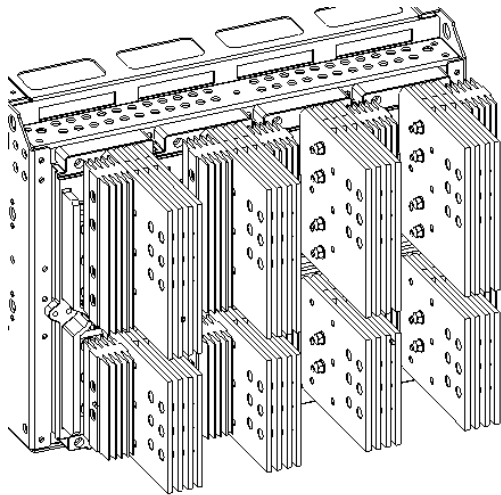
Fig G. Envelope 2, 3200A ANSI 3 Pole

**Back Connected Terminations Assembly (4 Pole)  
Procedure:**

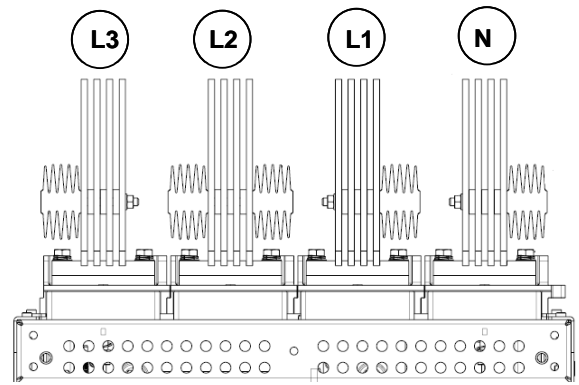
1. Similar Procedure to be followed for 4 pole breaker with neutral on right or left.
2. For 4 Pole breaker, assemble the L2 pole with two heat sinks first. Then assemble the adjacent poles with only one outer heat sinks. Refer Fig H – Fig L.



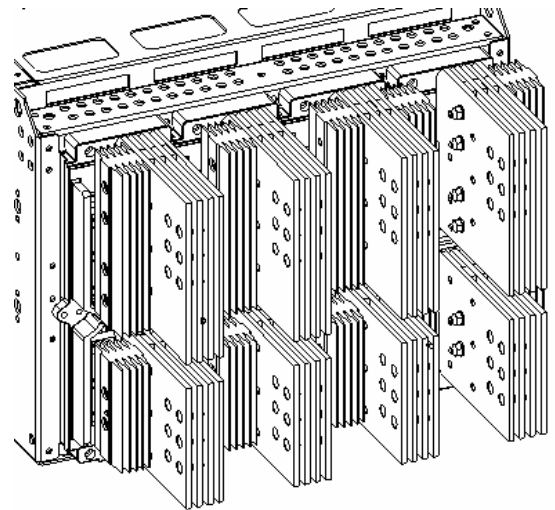
**Fig H. Envelope 2, 3200A ANSI 4 Pole, Neutral Left, Top view**



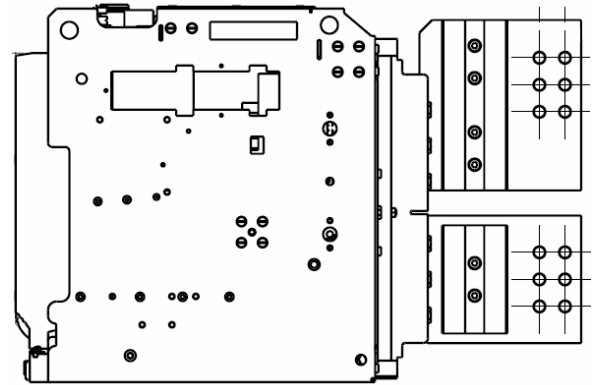
**Fig I. Envelope 2, 3200A ANSI 4 Pole, Neutral left, top View**



**Fig J. Envelope 2 , 3200A ANSI 4 Pole ,Neutral Right, Top view**



**Fig K. Envelope 2, 3200A ANSI 4 Pole, Neutral Right**



**Fig L. Envelope 2, 3200A ANSI 4 Pole Side view**

These instructions do not cover all details or variations in equipment nor do they provide for every possible contingency that may be met in connection with installation, operation, or maintenance. Should further information be desired or should particular problems arise that are not covered sufficiently for the purchaser's purposes, the matter should be referred to the ABB Inc.

—  
**ABB Inc.**  
305 Gregson Drive  
Cary, NC 27511.  
electrification.us.abb.com

—  
We reserve the right to make technical changes or modify the contents of this document without prior notice. With regard to purchase orders, the agreed particulars shall prevail. ABB Inc. does not accept any responsibility whatsoever for potential errors or possible lack of information in this document.

We reserve all rights in this document and in the subject matter and illustrations contained therein. Any reproduction or utilization of its contents – in whole or in parts – is forbidden without prior written consent of ABB Inc.  
Copyright© 2019 ABB  
All rights reserved