

Allen-Bradley

ControlNet Ex Media

1797-series

**Planning and Installation
Manual**

**Rockwell
Automation**

Important User Information

Solid state equipment has operational characteristics differing from those of electromechanical equipment. *Safety Guidelines for the Application, Installation and Maintenance of Solid State Controls* (Publication SGI-1.1 available from your local Rockwell Automation sales office or online at <http://www.ab.com/manuals/gi>) describes some important differences between solid state equipment and hard-wired electromechanical devices. Because of this difference, and also because of the wide variety of uses for solid state equipment, all persons responsible for applying this equipment must satisfy themselves that each intended application of this equipment is acceptable.

In no event will Rockwell Automation, Inc. be responsible or liable for indirect or consequential damages resulting from the use or application of this equipment.

The examples and diagrams in this manual are included solely for illustrative purposes. Because of the many variables and requirements associated with any particular installation, Rockwell Automation, Inc. cannot assume responsibility or liability for actual use based on the examples and diagrams.

No patent liability is assumed by Rockwell Automation, Inc. with respect to use of information, circuits, equipment, or software described in this manual.

Reproduction of the contents of this manual, in whole or in part, without written permission of Rockwell Automation, Inc. is prohibited.

Throughout this manual, when necessary we use notes to make you aware of safety considerations.

WARNING

Identifies information about practices or circumstances that can cause an explosion in a hazardous environment, which may lead to personal injury or death, property damage, or economic loss.

IMPORTANT

Identifies information that is critical for successful application and understanding of the product.

ATTENTION

Identifies information about practices or circumstances that can lead to personal injury or death, property damage, or economic loss. Attentions help you:

- identify a hazard
- avoid a hazard
- recognize the consequence

SHOCK HAZARD

Labels may be located on or inside the equipment (e.g., drive or motor) to alert people that dangerous voltage may be present.

BURN HAZARD

Labels may be located on or inside the equipment (e.g., drive or motor) to alert people that surfaces may be dangerous temperatures.

Preface	<ul style="list-style-type: none"> What's in This Chapter 1-1 Abbreviations and Symbols 1-2 Common Techniques 1-2 For More Information 1-2
Overview of the ControlNet Ex Media System	<p>Chapter 1</p> <ul style="list-style-type: none"> What This Chapter Contains 1-1 Understand the ControlNet Ex Media System 1-2 Understand ControlNet Ex Components 1-4 <ul style="list-style-type: none"> Nodes 1-4 Taps 1-4 Trunk Cable 1-5 Cable Connectors. 1-6 Trunk Terminator. 1-6 Tap Terminator 1-7 Segments. 1-7 Fiber Repeater Hubs 1-7 Network 1-8 Insulators 1-8 ControlNet Ex System Installation Requirements 1-9 <ul style="list-style-type: none"> Certified Equivalent ControlNet Ex System Components 1-10 UL, cUL I/O Entity Parameters and Requirements 1-11 European Community Directive Compliance 1-12 EMC Directive 1-12 Ex Directive. 1-13 What Is Next? 1-13 <p>Chapter 2</p> <ul style="list-style-type: none"> What This Chapter Contains 2-1 Determine How Many Taps You Need. 2-2 Connect Programming Devices in Safe Areas 2-3 Coax Cable Type 2-3 Fiber Media Type 2-4 Determine Trunk Cable Section Lengths. 2-4 <ul style="list-style-type: none"> Determine Trunk Cable Section Length When You Use a FLEX Ex Redundant ControlNet Barrier Module. 2-6 Estimate Fiber Media Lengths 2-7 Determine How Many Trunk Terminators You Need 2-7 Determine What Type of Connectors You Need 2-8 Use Redundant Media in a Hazardous Area 2-10 Application Considerations 2-13 <ul style="list-style-type: none"> Understand Conductor Categories. 2-13 General Wiring Guidelines 2-14 Ferrite Beads. 2-15 <ul style="list-style-type: none"> Required Ferrite Beads. 2-15 Add Ferrite Beads 2-16
Plan a ControlNet Ex Media System	

	Order Components	2-17
	General Planning	2-17
	Plan a Segment	2-17
	Plan Your Network	2-18
	Order Parts	2-18
	What Is Next?	2-20
	 Chapter 3	
Install a ControlNet Ex Media System	What This Chapter Contains	3-1
	Install the Trunk Cable	3-1
	Wire External to Enclosures	3-1
	Wire Inside Enclosures	3-2
	Mount the Taps.	3-2
	Select Where to Mount the Taps.	3-2
	Mount the Taps	3-3
	Specifications	3-6
	Install Fiber Hubs	3-6
	Installation in Zone 1	3-7
	Electrostatic Charge	3-7
	Select a Fiber Repeater Hub Mounting Location	3-8
	Mount the Fiber Repeater Hub	3-9
	Connect the Fiber Repeater Hub to a ControlNet Ex Network	3-11
	Install Cable Connectors	3-13
	Collect Your Tools	3-13
	Strip the Cable	3-14
	Test for Electrical Shorts and Continuity Between the Center Conductor and the Shield	3-19
	Attach the Connectors to the Cable	3-20
	Test for Electrical Shorts and Continuity Between the Connector Body and Pin	3-24
	Connect Cable Sections	3-25
	Terminate Segments	3-25
	Connect Devices	3-27
Install the 1797-BCNR Module	3-28	
	 Appendix A	
Mounting Dimensions	What This Appendix Contains	A-1
	Tap Placement	A-1
	Universal Mounting Bracket.	A-2

Adjust the Cable Strip Tool

Appendix B

What This Appendix Contains B-1
Calibrate the Cutting Blades. B-1
Reverse and Replace the Cutting Blades. B-3
Change the Memory Blade Holder. B-5

**Protect Your System Against
Electrostatic Discharge**

Appendix C

Index

What's in This Chapter

Use this manual to plan and install a ControlNet Ex media system. This manual describes the required components of an intrinsically-safe cable system and how to plan for and install these required components.

This manual targets the configuration of a ControlNet Ex system. However, since a ControlNet Ex system and a ControlNet system can be linked, it may be necessary to introduce and refer to concepts on the ControlNet side of the network.

Some configurations on a standard ControlNet system may not be possible within a ControlNet Ex configuration. Many of the installation methods and equipment for the ControlNet Ex system is the same as those available for the ControlNet system. However, some differences do exist. As you use this manual, note these differences.

The following tables describe where specific information is found in this manual.

For	See Chapter
Help understanding the ControlNet Ex Media System	1
Help planning a ControlNet Ex Media System	2
Installation of a ControlNet Ex Media System	3

For	See Appendix
Mounting dimensions (taps, universal mounting bracket, and repeater)	A
Adjusting the cable strip tool	B
Protecting your system against electrostatic discharge	C

ATTENTION



You must have fundamental knowledge about electronics and electrical codes to interpret and apply the concepts in this manual.

Abbreviations and Symbols

The following table explains abbreviations and symbols we use in this manual.

This	Means
PVC cable	polyvinyl chloride cable
FEP cable	fluorinated ethylene propylene cable
PLC processor	Allen-Bradley programmable logic controller
	network continues (other nodes not shown)

Common Techniques

We use the following conventions throughout this manual:

- bulleted lists indicate information, not procedural steps
- numbered lists indicate sequential step

TIP

This symbol identifies helpful tips.

For More Information

For more information, refer to the following:

- Electronic Data Sheets:
<http://www.ab.com/networks/eds/index.html>
- RSNetWorx and RSLinx Software Demos and Tutorials

Overview of the ControlNet Ex Media System

What This Chapter Contains Use this chapter to familiarize yourself with the ControlNet Ex media system. The following table describes what this chapter contains and where to find specific information.

For Information On	See Page
Understand the ControlNet Ex Media System	1-2
Understand ControlNet Ex Components	1-4
ControlNet Ex System Installation Requirements	1-9

This system is an intrinsically-safe system specifically designed for use in hazardous areas.

TIP

For information on installation requirements for hazardous areas, refer to NFPA 70 (National Electrical Code NEC), Article 500.

TIP

This publication describes how to plan and install a ControlNet Ex media system in a hazardous area. Refer to the following publications for information on how to plan and install a coax and fiber media system in a non-hazardous environment:

- CNET-IN002, ControlNet Coax Media Planning and Installation Manual
- CNET-IN001, ControlNet Fiber Media Planning and Installation Manual

ATTENTION

The ControlNet Ex media system cannot be used in a safe environment after it has been exposed to signals from a hazardous area.

Understand the ControlNet Ex Media System

The ControlNet Ex media system gives you the flexibility to design a communication network for your particular application. To take full advantage of this flexibility, spend sufficient time when you plan how to install your network before you assemble any of the hardware.

For information on installing ControlNet media in a hazardous area, refer to the ControlNet Coax Media Planning and Installation Manual, publication CNET-IN002.

Use the following figures and term definitions to understand the ControlNet Ex media system

Figure 1.1 ControlNet Coax to Fiber system for FLEX Ex

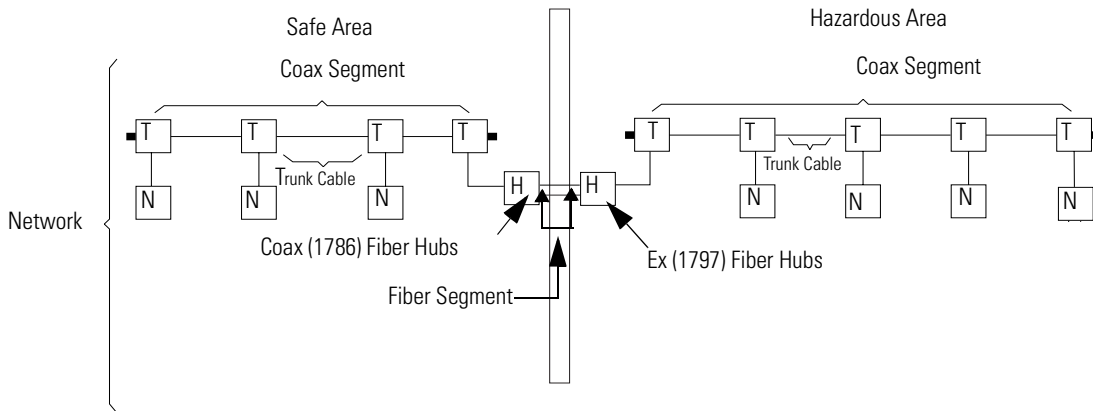

41326

Term	Means
Network	<ul style="list-style-type: none"> • A collection of connected nodes • A collection of nodes with unique addresses in the range of 1-99 • The connection paths between any pair of devices may include repeaters and bridges.
Segment	<ul style="list-style-type: none"> • Trunk cable sections connected via taps with terminators at each end and with no repeaters.
Trunk Cable	<ul style="list-style-type: none"> • The bus or central part of a media system
Trunk Cable Section	<ul style="list-style-type: none"> • A length of a cable between any two taps
Fiber Repeater Hub [H]	<ul style="list-style-type: none"> • Consists of a fiber repeater and fiber adapter • The components reconstruct and retransmit all traffic on one fiber or coax segment side to another coax or fiber segment side.
Tap [T]	<ul style="list-style-type: none"> • The connection between any device and the ControlNet Ex or ControlNet media system

Term	Means
Node N	<ul style="list-style-type: none"> Any physical device connecting to the ControlNet Ex or ControlNet media system that requires a network address to function on the network A network may contain a maximum of 99 nodes This address must be in the range of 1...99 and be unique to that network.
Trunk Terminator ■	<ul style="list-style-type: none"> A 75 Ω resistor mounted in a BNC plug
Tap Terminator D	<ul style="list-style-type: none"> Terminates a tap drop-cable that has yet to be connected to a node with a “dummy” node
Barrier B	<ul style="list-style-type: none"> Barrier for coax cable provides isolation between safe and hazardous areas
Repeater	<ul style="list-style-type: none"> A device that connects two or more segments together

You can also use the 1797-BCNR FLEX Ex Redundant ControlNet Barrier Module to interconnect between ControlNet coax and ControlNet Ex networks. This module provides an alternative to installing ControlNet Ex fiber repeater hubs.

Figure 1.2 ControlNet Coax barrier system for FLEX Ex

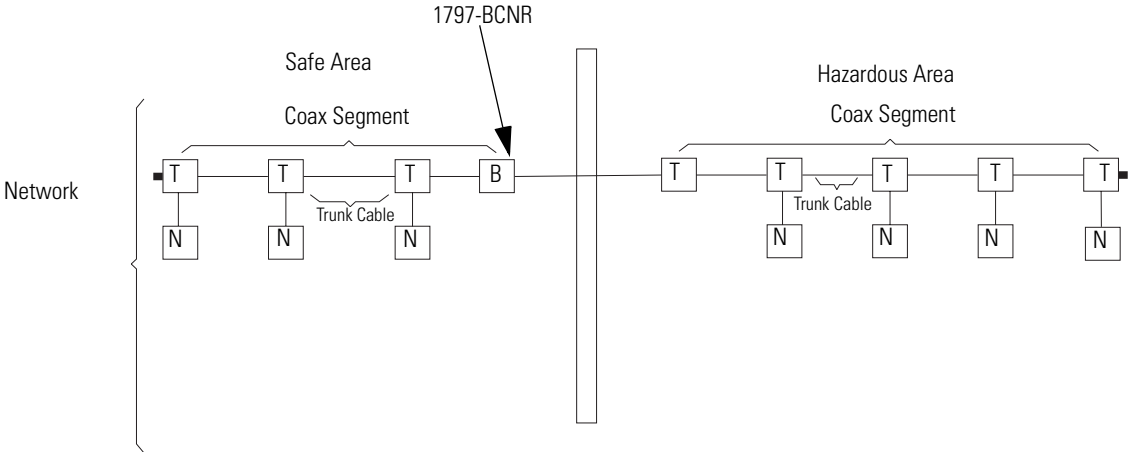

41326

Refer to Install the 1797-BCNR Module on page 3-28 for more information.

Understand ControlNet Ex Components

The ControlNet Ex media system is comprised of these components:

- Nodes
- Taps¹
- Trunk cable¹
- Cable connectors¹
- Terminators¹
- Segments
- Fiber repeater hubs (option)¹
- Tap terminator
- Network
- Insulators
- Coax barrier (option)¹

¹ For information about purchasing these components see the Allen-Bradley ControlNet Media Component List, publication AG-PA002.

Nodes

Nodes are defined as physical devices connected to the ControlNet Ex media system that require a network address to function on the network.

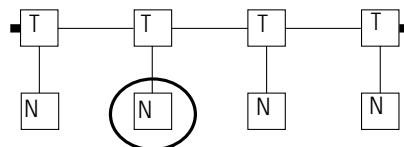

40953

Taps

Taps connect each node on a network to the coax media system via an integral 1 m (39.6 in.) drop cable.

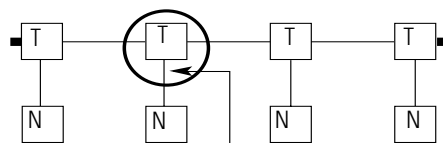

40944

There are four styles of taps available with:

- T or Y placement of BNC connectors

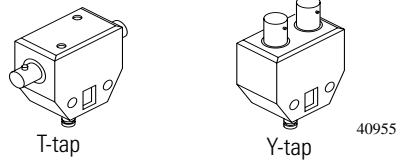

- Straight or right-angle connector on the drop media

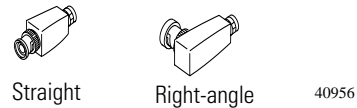
**ATTENTION**

Use only intrinsically-safe taps in a ControlNet Ex media system. Intrinsically-safe taps are marked “ControlNet Ex Tap.”

See page 2-2 for detailed information on taps.

Trunk Cable

The trunk cable is the bus, or central part of the ControlNet Ex coax media system. The trunk cable may be composed of multiple sections of cable. Quad-shield RG-6 type coax cable can be used to construct trunk cable sections.

ATTENTION

You must use either of these types of ControlNet Ex trunk cable:

- 1797-RG6, Belden 3092A
- Belden 3092A blue quad-shield RG-6 type coax cable

Cable Connectors

Use a cable connector (cat. no. 1786-BNC) to attach coax trunk cable sections to the tap's BNC connector.

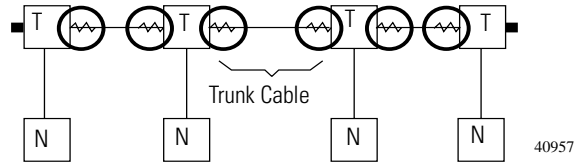

Optional Connectors

Rockwell Automation also offers optional cable connectors for use in your network configuration. See page 2-8 for available connectors.

Trunk Terminator

A 75 Ω terminator (cat. no. 1797-XT) **must** be installed on the tap at each end of a segment.

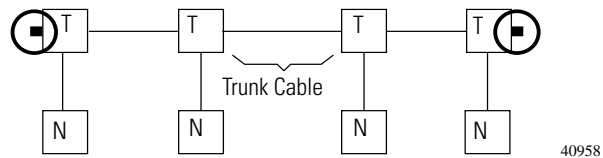

ATTENTION



Use only intrinsically-safe trunk terminators in a ControlNet Ex media system. Intrinsically-safe trunk terminators are marked “CNet Ex Trk Trm.”

Tap Terminator

A tap terminator (cat. no. 1797-TCAP) is available to terminate unused taps.

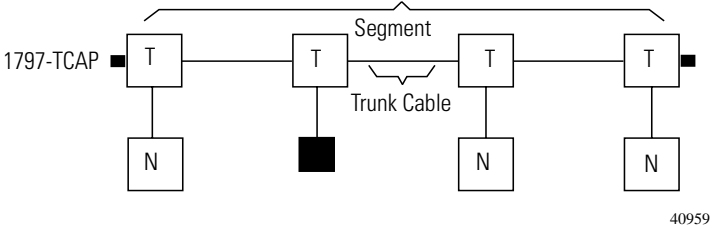

ATTENTION



Use only intrinsically-safe tap terminators in a ControlNet Ex media system. Intrinsically-safe tap terminators are marked “CNet Tap Trm.”

Segments

A segment is a collection of coax trunk cable sections, taps, and two terminators.

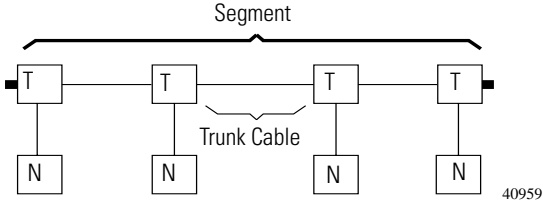

The total allowable length of a segment depends upon the number of taps in your segment and the coax cable type used.

See page 2-1 for detailed information.

Fiber Repeater Hubs

You can use fiber as the connector from your safe area to your hazardous area. Use fiber repeaters to connect the coax cable to the fiber. Fiber repeater hubs increase the number of taps, extend the total length of your segment, or create a star configuration (go off in multiple directions from one point). The number of fiber repeater

hubs and cable length total are limited depending on your network topology. You can have a maximum of 5 repeaters in series.

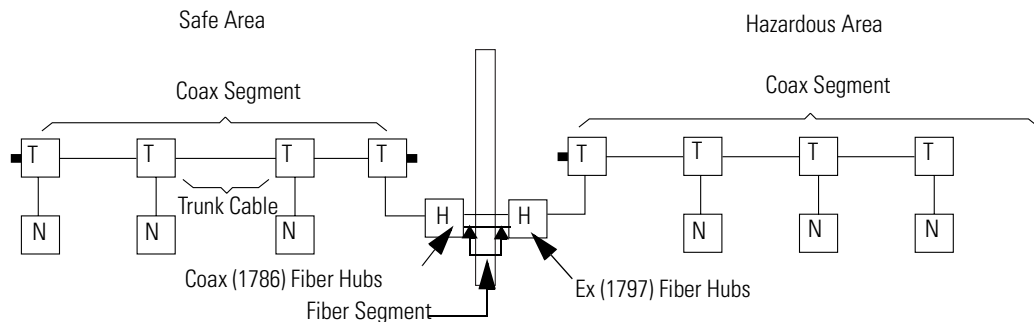

41327

When you insert a fiber repeater hub into your cable system, you create a new segment. The same restrictions on the number of taps and cable length apply to this new segment.

ATTENTION

Use only the intrinsically-safe 1797 version of the fiber repeater hub in the hazardous area.



Network

A ControlNet network is the collection of connected segments, fiber repeater hubs, and nodes.

Insulators

The ControlNet Ex media system must maintain isolation from ground. Many of the connectors have metal parts. These parts must be insulated from ground contact by 500V insulation material. Insulators are provided with ControlNet Ex media system components that require insulation. For example, the ControlNet Ex taps are supplied with an insulator kit.

A large variety of BNC connectors are available for use with the ControlNet Ex media system. As a result, insulators for all types of connectors are not available. In these cases, wrapping the exposed metal with 500V insulation electrical tape is acceptable.

Two insulator kits are available:

- Catalog number 1797-BOOT provides standard BNC trunk cable insulators.
- Catalog number 1797-INS provides a variety of the preformed boots and insulators used with the ControlNet Ex system products.

ControlNet Ex System Installation Requirements

You can connect a maximum of 48 ControlNet Ex taps with a total of 250m of coax cable when using fiber hub architecture. The maximum distance increases to 1000m when you use only 2 taps.

Refer to Determine Trunk Cable Section Lengths on page 2-4 and see the table below for more information.

Catalog Number	Catalog Name	Description
1797-RPA	ControlNet Ex Modular Repeater Adapter	Represents one ControlNet Ex node and must be connected to a coax trunk cable by 1797-TPx
1797-RPFM	ControlNet Ex Fiber Repeater Module, Medium Distance	Allows connection of a maximum of two devices per 1797-RPA and is powered directly by 1797-RPA
1797-ACNR15	Redundant Media ControlNet Ex Adapter	Represents one ControlNet Ex node and must be connected to a coax trunk cable by 1797-TPx -each one with two redundant output channels that are connected to different ControlNet Ex networks (coax cables and 1797-TPx)
1797-BCNR	FLEX Ex Redundant ControlNet Barrier Module	Galvanic isolation barrier for signal between the non-intrinsic ControlNet system an intrinsically-safe ControlNet Ex system.
1797-TCAP	ControlNet Ex Tap (Dummy) Terminator	Represents one ControlNet Ex node and is a simple capacitor (56pF) with a coax connector
1797-TPx	ControlNet Ex Coax Tap	Four types of connections available: S (straight T-tap), R (right angle T-tap), YS (straight Y-tap), and YR (right angle Y-tap) - a maximum of 48 taps can be connected by coax trunk cable
1797-XT	ControlNet Ex Trunk Terminator	Simple resistor (75 Ω) with coax connector that must be on each end of the ControlNet Ex coax trunk for termination

Catalog Number	Catalog Name	Description
1786-RG6	Quad-Shield, RG-6 75Ω Coax Trunk Cable	Maximum (functional) length between two 1797-TPx is 3280ft (1000m) - each 1797-TPx reduces the (functional) coax cable length by 16.3 m (53.4 ft)
1786-BNCP, -BNCJ, BNCJI	Standard Coax Trunk Cable BNC Couplers	Standard cable couplers
1797-BOOT	FLEX Ex Boot Insulator Kit	Replacement insulators

You can install fiber connecting the 1797-RPFM module with any approved associated device throughout the safe location.

All cables and fiber media that are not light blue must be marked as IS using the 1797-EXMK marking kit or other locally approved IS identification or segregation method.

ATTENTION



You must isolate all metallic parts during the installation of the ControlNet Ex system to prevent an earth connection. Use dielectric-strength isolating material. The isolating material must withstand voltages > 500V ac.

Certified Equivalent ControlNet Ex System Components

You may use these items as equivalents for system components.

Component	Catalog Number	Source
Coax Trunk Cable	1797-RG6	Rockwell Automation
	3092IS ¹	Belden Wire & Cable Co.
	3092A with blue jacket	Belden Wire & Cable Co.

¹ Belden Wire & Cable 1189A may be used, but with functional loss of communication distance or nodes.

UL, cUL I/O Entity Parameters and Requirements

TIP

For more information on UL and cUL installation requirements, refer to publication 1797-RM001, FLEX Ex System Certification Reference Manual.

Terminals	V _t (V)	I _t (mA)	Groups	C _a (μF)	L _a (μH)
Male Bus Connector	5.8	400	A-G	3.0	3.0

The entity concept allows interconnection of intrinsically-safe apparatus with associated apparatus not specifically examined in combination as a system when the approved values of V_{oc} and I_{sc} or V_t and I_t of the associated apparatus are less than or equal to V_{max} and I_{max} of the intrinsically-safe apparatus and the approved values of C_a and L_a of the associated apparatus are greater than C_i + C_{cable} and L_i + L_{cable} respectively for the intrinsically-safe apparatus.

Wiring methods must be in accordance with the National Electric Code, ANSI/NFPA 70, Article 504 and 505 or the Canadian Electric Code CSA C22.1, Part 1, Appendix F. For additional information refer to ANSI/ISA RP12.6.

WARNING



Substitution of components may impair the intrinsic safety of this system.

AVERTISSEMENT: La substitution de composant peut compromettre la securite intrinseque.

If fiber optic cable is provided with a metal shield, it must be connected to a dedicated intrinsic safety ground in the intrinsically-safe location and isolated in the non-intrinsically-safe location or be connected to a ground in the hazardous location and isolated in the intrinsically-safe location.

The glass fiber must have a minimum diameter of 6 μ m.

European Community Directive Compliance

The ControlNet Ex System has the CE mark. It is approved for installation within the European Community or EEA regions. It has been designed and tested to meet the following directives.

EMC Directive

The ControlNet Ex System is tested to meet the Council Directive 89/336/EC Electromagnetic Compatibility (EMC) by applying the following standards, in whole or in part, documented in a technical construction file:

- EN50081-2 — EMC - Generic Emission Standard, Part 2 - Industrial Environment
- EN50082-2 — EMC - Generic Immunity Standard, Part 2 - Industrial Environment

The ControlNet Ex System is intended for use in an industrial environment.

Ex Directive

The ControlNet Ex System is tested to meet the Council Directive 94/9 EC (ATEX 100a) Equipment and Protective Systems Intended for Use in Potentially Explosive Atmospheres by applying the following standards:

- EN50014:1992, Electrical Apparatus for Potentially Explosive Atmospheres
- EN50020:1994, Electrical Apparatus for Potentially Explosive Atmospheres - Intrinsic Safety “i”
- EN50039:1980, Electrical Apparatus for Potentially Explosive Atmospheres - Intrinsically-safe Electrical Systems “i”
- pr EN50284:1997, Special requirements for construction, test, and marking of electrical apparatus of equipment group II, category 1 G

What Is Next?

Now that you have a general understanding of the ControlNet Ex media system, you are ready to go to Chapter 2 to design a ControlNet Ex media system for your specific requirements.

Notes:

Plan a ControlNet Ex Media System

What This Chapter Contains Read this chapter to determine your network requirements.

For	See Page
Determine How Many Taps You Need	2-2
Connect Programming Devices in Safe Areas	2-3
Coax Cable Type	2-3
Fiber Media Type	2-4
Determine Trunk Cable Section Lengths	2-4
Estimate Fiber Media Lengths	2-7
Determine How Many Trunk Terminators You Need	2-7
Determine What Type of Connectors You Need	2-8
Use Redundant Media in a Hazardous Area	2-10
Application Considerations	2-13
Ferrite Beads	2-15
Order Components	2-17

After reading this chapter, consult engineering drawings of your facility for specific information concerning the best location for installing your network.

TIP

The ControlNet Ex media system is a ground-isolated network. To help prevent accidental grounding:

- Properly select cable, connectors, and accessories. Local agencies require use of these items for intrinsically safe system certification.
- Use the supplied light-blue intrinsically-safe insulators and dust caps to cover exposed metal parts.
- Any accessories should have a dielectric rating of greater than 500V.
- Use good installation techniques.
- Use blue tape to help prevent metal-to-ground connections.

Determine How Many Taps You Need

The number of taps you need depends on the number of devices you want to connect to the network. You need a tap for each node, repeater, or fiber hub on the network.

If you plan to add nodes later, you should consider ordering and installing the cable and connectors for these additional nodes when you install the initial network. This will minimize disruption to the network during operation.

TIP

A disconnected drop cable can cause noise to enter the network. Because of this, we recommend that you have **only one** unconnected tap per network for maintenance purposes. Use a tap terminator, catalog number 1797-TCAP, on any unconnected drop cable.

TIP

If you are planning future installation of additional nodes, and can tolerate losing communication for a short time, do not install the tap. Instead, install a BNC bullet connector, catalog number 1786-BNCJ. See page 2-8 for more information on the 1786-BNC bullet connector.

Each tap kit contains the following pieces:

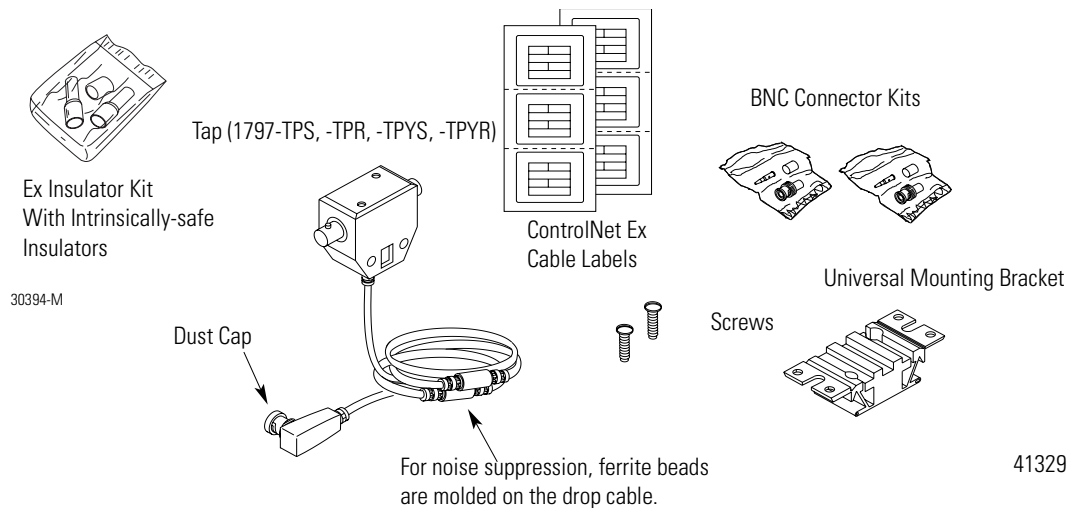

TIP

We provide the light-blue intrinsically-safe insulators and dust caps to cover exposed metal parts. Use these items for intrinsically safe system certification by local agencies.

These tap kits are available (dust caps not shown):

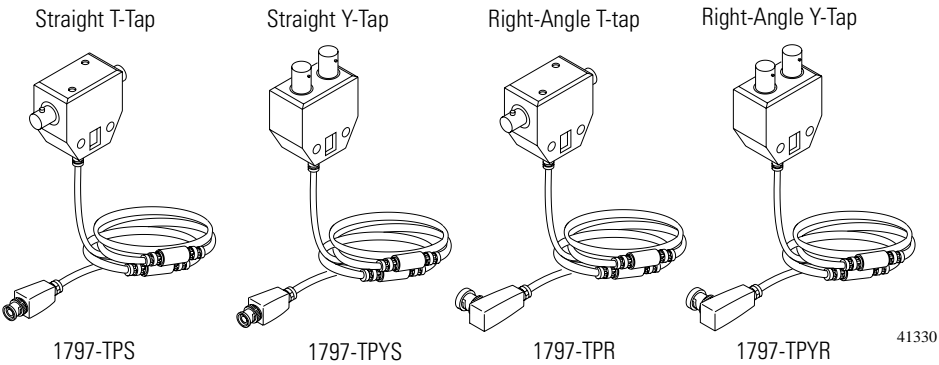

Connect Programming Devices in Safe Areas

Connect programming devices in safe areas to the ControlNet cable system through a 1784-KTCX15 communication card. Use a ControlNet tap to connect the communication card to the network.

Figure 2.1 Use a 1784-KTCX15 Communication Card on Coax Media

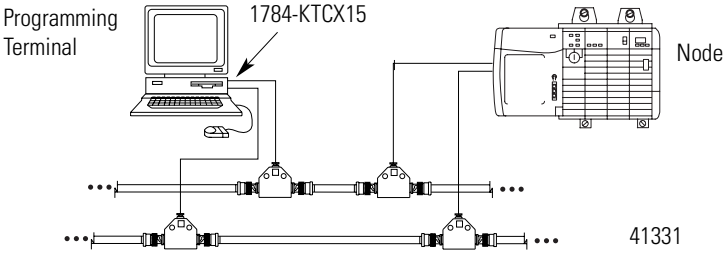

Coax Cable Type

You must use 1786-RG6, Belden 3092A, or Belden 3092A blue quad-shield RG-6 coax cable as the ControlNet Ex trunk cable.

Fiber Media Type

Fiber media type specifications are listed below.

- Fiber type 62.5/125 μ
- Connector type ST (plastic or ceramic)
- Operating wavelength 1300 nm
- Optical power budget 13.3 dB

You should install all fiber for your ControlNet Ex cable system in accordance with the regulations contained in applicable country codes, state codes, and applicable municipal codes (for example, National Electric Code). All metal connectors must be insulated from the ground. Use blue ControlNet cable or the ControlNet Ex Cable Marking Kit (1797-EXMK) to mark cable as intrinsically-safe. When you use the 1797-EXMK, be certain to place one marker at every meter of length.

Determine Trunk Cable Section Lengths

A segment is comprised of several sections of trunk cable separated by taps. The total cable length of a segment is equal to the sum of all of the trunk cable sections, including taps.

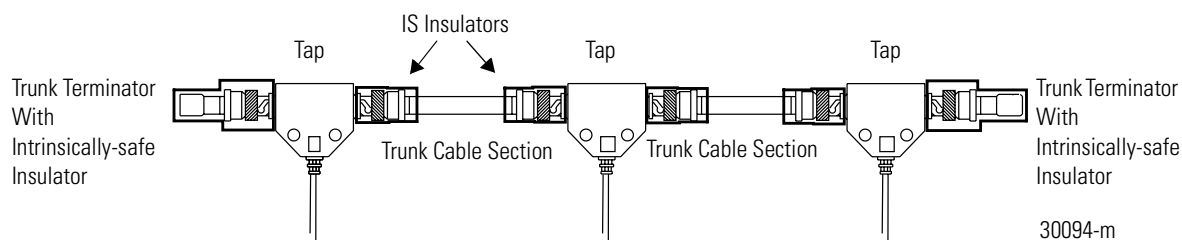

TIP

When determining the length of trunk cable sections, measure the actual cable path as it is routed in your network. Consider vertical dimensions as well as horizontal dimensions. You should always calculate the three-dimensional routing path distance when determining cable lengths.

Cover all exposed metal on connectors with either the intrinsically-safe insulators or other forms of insulation.

Select the shortest path for routing the cable to minimize the amount of cable you need. The specific details of planning such a cable route depends upon the needs of your network.

The total allowable length of a segment containing standard RG-6 quad-shield cable depends upon the **number of taps** in your segment. There is **no minimum** trunk cable section length

requirement. The maximum allowable total length of a segment is 1,000 m (3,280 ft) with two taps connected. Each additional tap decreases the maximum length of the segment by 16.3 m (53.4 ft). The maximum number of taps allowed on a segment is 48 with a maximum length of 250 m (820 ft).

IMPORTANT

The derating curve is applicable only when the cable meets ControlNet attenuation specifications.

Figure 2.2 ControlNet Single Media Derating Curve

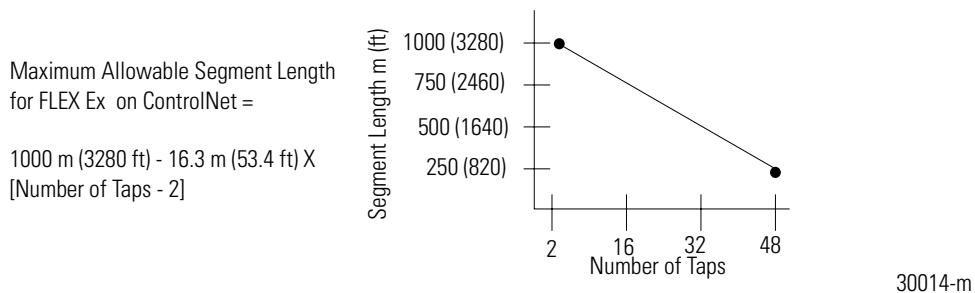

EXAMPLE

If your segment requires 10 taps, the maximum segment length is:

$$1000\text{m (3280 ft)} - 16.3 \text{ m (53.4 ft)} \times [10 - 2]$$

$$1000\text{m (3280 ft)} - 130.4 \text{ m (427.7 ft)} = 869.6 \text{ m (2852.3 ft)}$$

An allowable total length of RG-6 cable segment in your application can be determined by using the equation below. Each additional tap decreases the maximum length of the segment. The maximum number of taps allowed on a segment is 48. Each additional tap decreases the maximum length of the segment.

IMPORTANT

This equation applies when the cable does not meet ControlNet attenuation specifications.

Maximum Allowable Segment Length of Cable =

$$\frac{(20.29 \text{ db} - \text{Number Of Taps in Segment} \times .32 \text{ db})}{\text{Cable Attenuation @ 10 MHz per 304 m (1000 ft)}} \times 304 \text{ m (1000 ft)}$$

Note: Cable attenuation is defined as the signal loss measured at 10 MHz per 304 m (1000 ft) of cable. Cable attenuation for ControlNet Ex cables is listed in the ControlNet Ex Media Component List, publication AG-PA002.

EXAMPLE If your segment requires 3 taps using 1786-RG6 cable, the maximum segment length is:

$$([20.29 \text{ db} - 3 \cdot 3.32 \text{ db}] / 5.99 \text{ db}) \cdot 304$$

$$(19.33 \text{ db} / 5.99 \text{ db}) \cdot 304 = 982 \text{ m (3227 ft)}$$

IMPORTANT The total trunk cable length or number of taps can be increased by installing a repeater hub on the segment. This creates another segment.

For redundant media, decrease the number of taps by half, as shown in the derating curve.

Figure 2.3 ControlNet Redundant Media Derating Curve

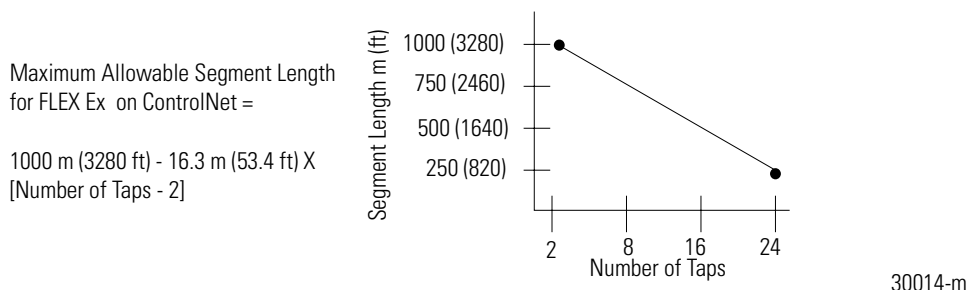

Determine Trunk Cable Section Length When You Use a FLEX Ex Redundant ControlNet Barrier Module

When you use a FLEX Ex Redundant ControlNet Barrier Module (catalog no. 1797-BCNR), the total allowable length of a segment containing standard RG-6 quad-shield cable depends upon the number of taps in your segment. There is no minimum trunk cable section length requirement. The maximum allowable length of a segment that contains a 1797-BCNR module is 500 m. (1640 ft) with two taps connected. Each additional tap decreases the maximum length of the segment according to the derating curve. The maximum number of taps allowed on a segment is 20 with a maximum length of 250 m (820 ft).

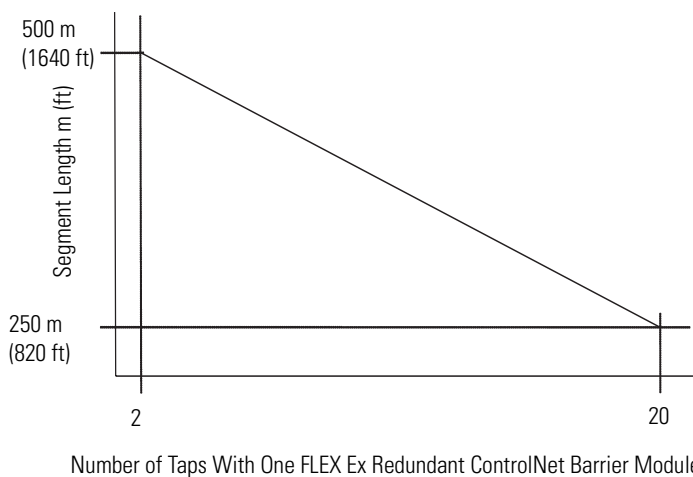

Estimate Fiber Media Lengths

The maximum length of a fiber media section for the 1797-RPFM module is dependent on the quality of the fiber, number of splices, and the number of connectors. The total attenuation for a cable section **must** be less than 13.3 dB.

Typically, cable attenuation for a wavelength of 1300 nm is less than 1.5 dB/km.

IMPORTANT

Avoid joining cable with connectors as much as possible. Connectors can cause considerable attenuation and limit the maximum length of your system. Be sure to check the attenuation of each cable sections after the cable is installed.

Determine How Many Trunk Terminators You Need

You must use 75 Ω trunk terminators equipped with intrinsically-safe insulators (cat. no. 1797-XT) at the end of each segment in the ControlNet Ex cable system.

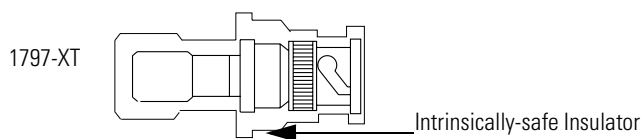



After you have determined the number of segments in your network, multiply this number by two to determine how many terminators you need for your network.

IMPORTANT

To comply with intrinsic safety standards, be sure to cover the exposed metal with the intrinsically-safe insulator provided with each terminator.

Determine What Type of Connectors You Need

Use the following table to determine what type of connectors you need.

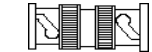
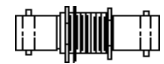
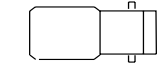
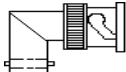
Use This BNC Connector	To	Cat. No.
cable connector 	Attach trunk cable sections to a tap's BNC connector	1786-BNC
Use This Optional BNC Connector	To	Cat. No.
Bullet (Jack-to-jack) 	Reserve a space in the trunk cable for future installation of a tap or to splice a trunk cable	1786-BNCJ
Barrel (Plug-to-plug) 	Connect two adjacent taps without a trunk cable section between them	1786-BNCP
Isolated-bulkhead (Jack-to-jack) 	Go through grounded panel walls while maintaining the shield isolation of the trunk cable	1786-BNCJI
Tap Terminator 	Cap off installed taps that have yet to be connected to a node	1797-TCAP
Right Angle (Jack-to-plug) 	Provide a 90° bend in your cable (prevent bending your cable excessively) See Chapter 3 for the bend radius specification	Refer to the ControlNet Media System Component List, publication AG-PA002 for the part number

In This Example, ControlNet Ex Cable:

- Enters and exits the panel enclosure from the side using isolated-bulkhead connectors
- Contains two adjacent taps connected by a barrel connector
- Reserves one future tap location with a bullet

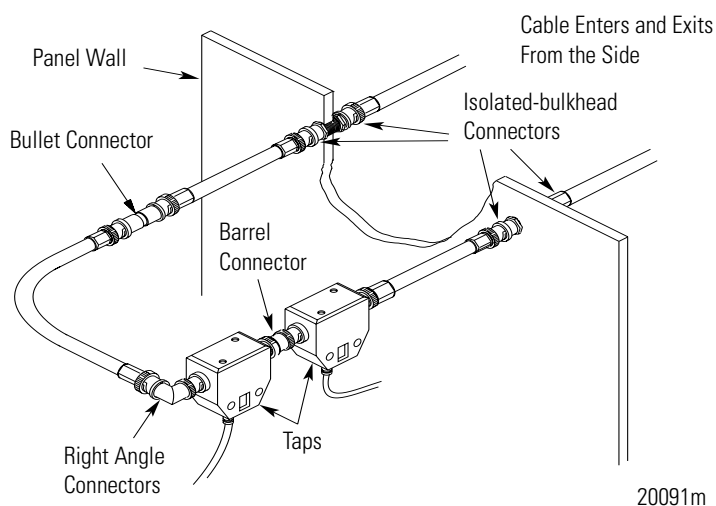

ATTENTION



Do not let any metallic surfaces on the BNC connectors, plugs, or optional accessories touch grounded metallic surfaces. This contact could cause noise on the network. All exposed metal must be covered with either intrinsically-safe blue insulators or another form of insulation, such as tape with a 500V rating.

TIP

If you install a bullet connector for future tap installations, count the bullet as one of the tap allotments on your segment (and decrease the maximum allowable cable length by 16.3 m [53.5 ft]).

This helps you avoid reconfiguring your network when you install the tap.

Use Redundant Media in a Hazardous Area

You can run a second trunk cable between your ControlNet Ex nodes for redundant media. With redundant media, nodes send signals on two separate segments. The receiving node compares the quality of the two signals and accepts the better signal to permit use of the best signal. This also provides a backup cable should one cable fail.

Trunk cables on a redundant cable network are defined by the segment number and the redundant trunk cable letter.

Actual ControlNet Ex products are labeled with these icons  (the shaded icon represent redundant media).

In this figure, the redundant cable trunk cable is trunk cable B.

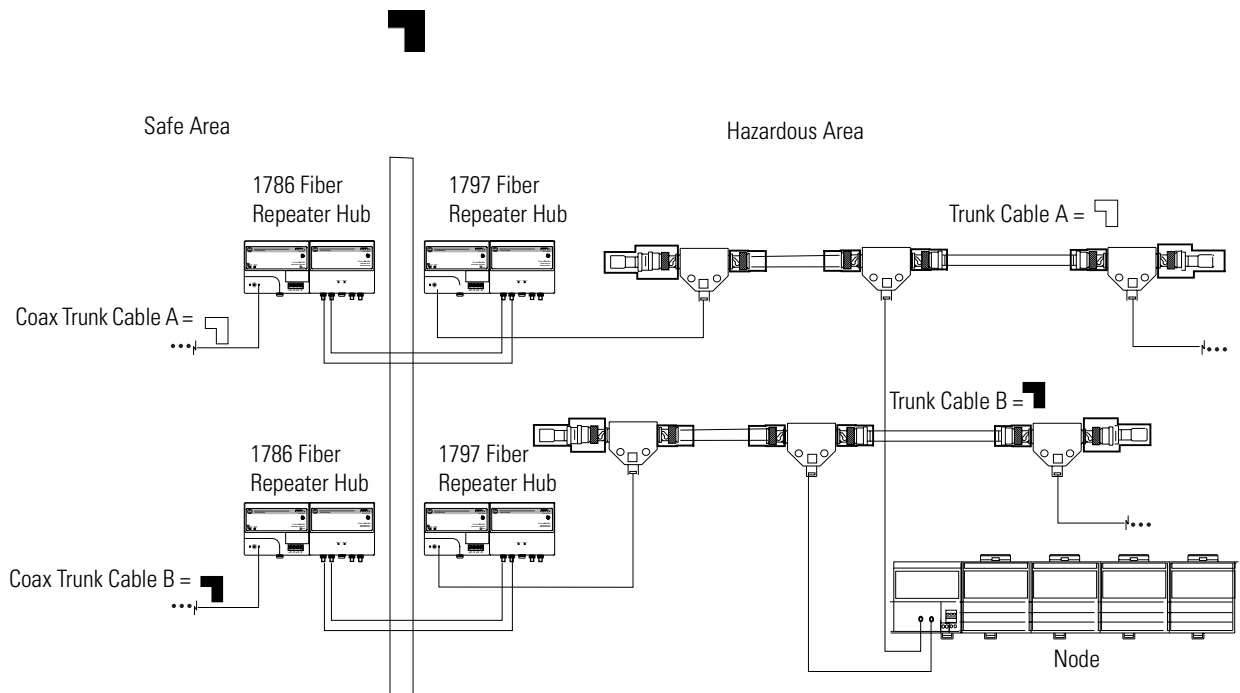

41346

Observe the following guidelines when planning a redundant media system in a hazardous area.

- Route the two trunk cables (trunk cable A and trunk cable B) differently to reduce the chance of both cables being damaged at the same time.
- Each node on a redundant-cable network must support redundant coax connections and be connected to both trunk cables at all times. Any nodes connected to only one side of a redundant-cable network will result in media errors on the unconnected trunk cable.

- Install the cable system so that the trunk cables at any physical device location can be easily identified and labeled with the appropriate icon or letter. Each redundant ControlNet Ex device is labeled so you can connect it to the corresponding trunk cable.
- Both trunk cables (trunk cable A and trunk cable B) of a redundant-cable network must have identical configurations. Each segment must contain the same number of taps, nodes and fiber repeaters. Connect nodes and fiber repeaters in the same relative sequence on both trunk cables.
- Either side of a redundant-cable network may differ in cable length. The total difference in length between the two trunk cables must not exceed 800 m (2640 ft).

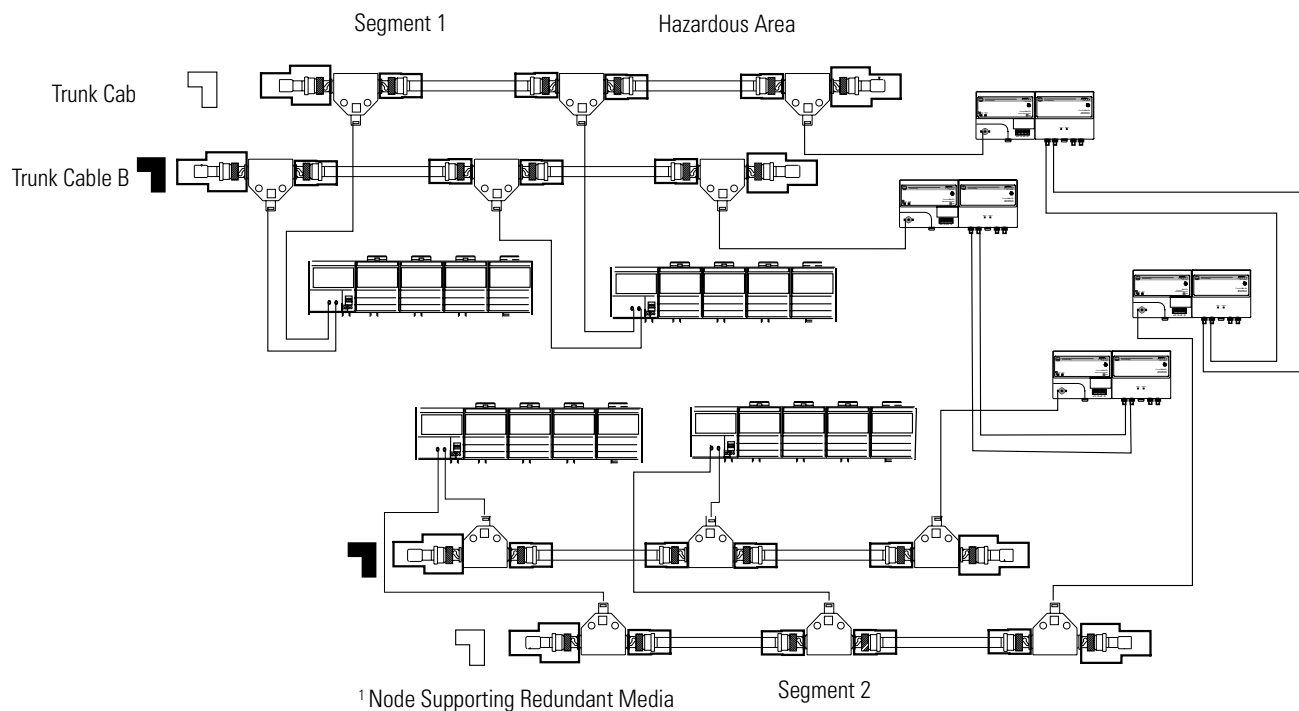

- Avoid connecting a single node's redundant trunk cable connections on different segments; this will cause erratic operation.

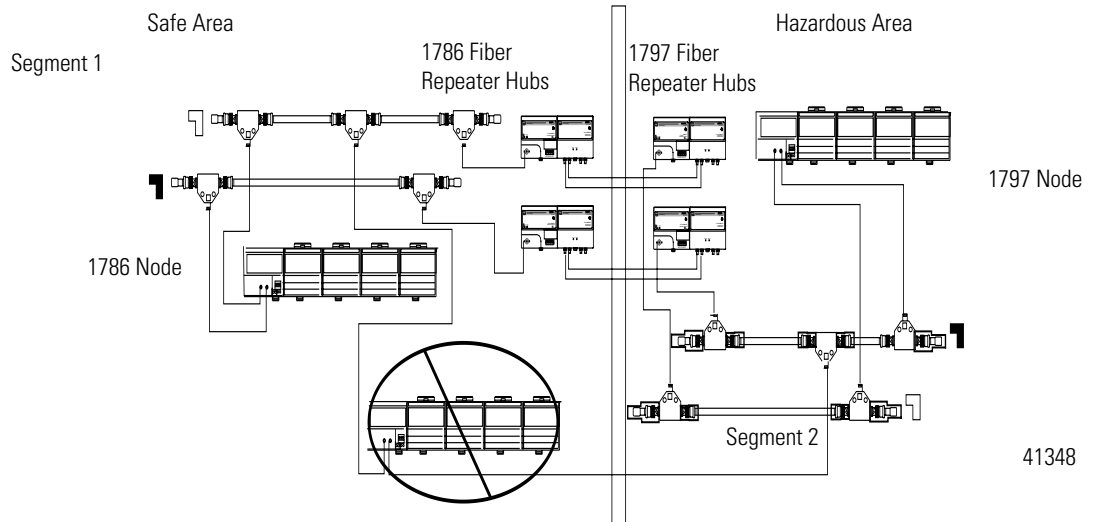

A node supporting redundant trunk cable connections will function even if trunk cable A is connected to the B connector on the node and vice-versa. This makes cable fault indications (on the hardware or in software) difficult to interpret and makes locating a bad cable segment very difficult.

ATTENTION



Never connect parts of a ControlNet cable system to those of a ControlNet Ex cable system. The 1786 fiber repeater hub and 1797 fiber repeater hub are used to isolate the two sections of a ControlNet network.

ATTENTION



ControlNet Ex products cannot be used in an intrinsically-safe environment after they have been exposed to non-intrinsically-safe signals.

Application Considerations

The following guidelines coincide with the guidelines for the installation of electrical equipment to minimize electrical noise inputs to controllers from external sources contained in IEEE standard 518-1982. When planning your cable system keep these installation considerations in mind.

ATTENTION



These guidelines apply only to noise coupling. Intrinsic safety requirements for cable mounting are of the highest priority.

Understand Conductor Categories

Conductors can be divided into three categories.

Category	Includes
1	ac power lines High-power digital ac I/O lines High-power digital dc I/O lines Power connections (conductors) from motion drives to motors
2	Analog I/O lines and dc power lines for analog circuits Low-power digital ac/dc I/O lines Low-power digital I/O lines ControlNet Ex communication cables
3	Low-voltage dc power lines Communication cables to connect between system components within the same enclosure

General Wiring Guidelines

Follow these guidelines with regard to noise coupling. Following intrinsic safety requirements should prevent most or all of these situations from occurring. These guidelines are provided as a general reference for wiring.

- If wiring must cross power feed lines, it should do so at right angles.
- Route wiring at least 1.5 m (5 ft) from high-voltage enclosures, or sources of rf/microwave radiation.
- If the conductor is in a metal wireway or conduit, each section of that wireway or conduit must be bonded to each adjacent section so that it has electrical continuity along its entire length, and must be bonded to the enclosure at the entry point.

For more information on general wiring guidelines, see the Industrial Automation Wiring and Grounding Guidelines, publication 1770-4.1.

Wire External to Enclosures

Cables that run outside protective enclosures are relatively long. To minimize cross-talk from nearby cables, you should maintain maximum separation between the ControlNet Ex cable and other potential noise conductors. Route your cable following these guidelines:

Cable in a Contiguous Metallic Wireway or Conduit?	Route Your Cable At Least	From Noise Sources of This Strength
Yes	0.08 m (3 in.) 0.15 m (6 in.) 0.3 m (12 in.)	Category-1 conductors of less than 20A ac power lines of 20A or more, up to 100 KVA ac power lines greater than 100 KVA
No	0.15 m (6 in.) 0.3 m (12 in.) 0.6 m (24 in.)	Category-1 conductors of less than 20A ac power lines of 20A or more, up to 100 KVA ac power lines greater than 100 KVA

Wire Inside Enclosures

Cable sections that run inside protective equipment enclosures are relatively short. As with wiring external to enclosures, you should maintain maximum separation between your ControlNet Ex cable and Category-1 conductors.

When you run cable inside an enclosure, route conductors external to all raceways in the same enclosure, or in a raceway separate from Category-1 conductors.

Route Your Cable At Least	From Noise Sources of This Strength
0.08 m (3 in.)	Category 1 conductors of less than 20 A
0.15 m (6 in.)	ac power lines of 20A or more, up to 100 KVA
0.6 m (24 in.)	ac power lines greater than 100 KVA

Surge Suppression

Transient electromagnetic interference (emi) can be generated whenever inductive loads such as relays, solenoids, motor starters, or motors are operated by hard contacts such as push-button or selector switches. These wiring guidelines assume you guard your system against the effects of transient emi by using surge-suppressors to suppress transient emi at its source.

Inductive loads switched by solid-state output devices alone do not require surge suppression. However, inductive loads of ac output modules that are in series or parallel with hard contacts require surge-suppression to protect the module output circuits as well as to suppress transient emi.

Ferrite Beads

Ferrite beads provide additional suppression of transient emi. Fair-Rite Products Corporation manufactures a ferrite bead (part number 2643626502) that can be slipped over Category-2 and Category-3 (RG-6 type trunk cable) conductors. You can secure them with heat-shrink tubing or tie-wraps. A cable transient emi induced onto the cable can be suppressed by a ferrite bead located near the end of the cable. The ferrite bead will suppress the emi before it enters the equipment connected to the end of the cable.

Required Ferrite Beads

Five ferrites come with each ControlNet Ex adapter. Four are identical and are for use on the ControlNet Ex trunk cable (two for Segment 1 and two for Segment 2). The fifth ferrite is longer. You use this ferrite on the adapter power cable.

Add Ferrite Beads

Wrap the IS power input cable two turns around the ferrite bead before connecting the terminal block to the adapter.

Five ferrite beads come with the adapter. Four are short and identical. Use these on the ControlNet Ex trunk cable. The fifth, longer ferrite bead is for the adapter power cable.

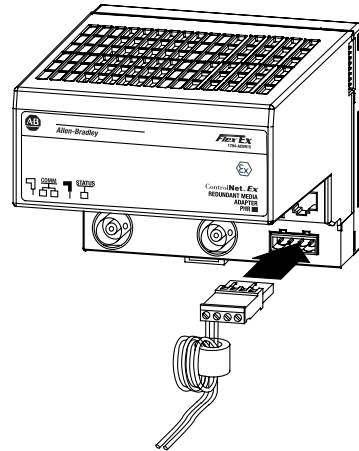

42206

Add ferrite beads on the ControlNet Ex trunk cable inside the cabinet wherever the trunk cable goes into or out of the cabinet.

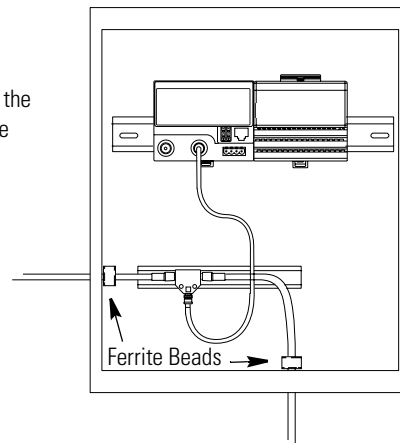

30890-M

Order Components

Now that you are ready to begin ordering components, use these guidelines to help you select components.

General Planning

The ControlNet Ex cable system is isolated from earth and must be protected from inadvertent ground connections.

Plan a Segment

Refer to this list when you plan a segment.

- All connections to the trunk cable require a tap
- Taps may be installed at any location on the trunk cable
- Tap drop-cable length must not be changed
- Maximum number of taps = 48, with 250 m (820 ft) of standard RG-6 trunk cable
- Maximum trunk cable length of RG-6 trunk cable = 1000 m (3280 ft), with 2 taps
- 75 Ω trunk terminators are required on both ends
- One tap with an unconnected drop cable may be installed for maintenance purposes
- Use BNC bullet connectors at future tap locations
- Do not mix redundant and non-redundant nodes
- Use ControlNet Ex tap terminators (1797-TCAP) for all other unconnected drop cables
- Avoid high noise environments when routing cables
- A supplied ferrite toroid should be used on the ControlNet Ex trunk as it enters and leaves control cabinets

Plan Your Network

Refer to this list when you plan your network.

- Maximum of 99 nodes (excluding fiber repeater hubs)
- Fiber repeater hubs require a tap but are not counted as nodes (they are included in the number of devices allowed per segment [48])
- Fiber repeater hubs may be installed at any tap location along a segment
- There can be only one path between any two points on a network
- The configuration of both sides of a redundant segment must be the same
- The total cable difference between the two sides of a redundant network cannot exceed 800 m (2640 ft)

Order Parts

The following table contains a list of ControlNet Ex Components. Refer to the ControlNet and ControlNet Ex Media System Components List, publication AG-PA002, for a list of other ControlNet parts.

Item	Cat. No.	Guidelines	Required Quantity ¹
Taps Straight T-tap Straight Y-tap Right-angle T-tap Right-angle Y-tap	1797-TPS 1797-TPYS 1797-TPR 1797-TPYR	You need a tap for each connection to the trunk cable (nodes and repeaters). Each tap kit contains: two BNC connector kits, one dust cap, one universal mounting bracket, ControlNet Ex cable labels and two screws	Number of repeaters x 2 + Number of nodes
Trunk Terminators	1797-XT (quantity of 50)	You need a terminator for each end of each segment.	Number of segments x 2
Trunk Cable		Use the ControlNet Ex Media System Component List, publication AG-PA002, to order your required length of cable.	Follow guidelines on page 2-4 of this document to determine cable length
Tap Terminator	1797-TCAP (quantity of 5)	Use the dummy load to plug into drop cables that are not attached to a node.	One for every drop cable that is not attached to a node

Item	Cat. No.	Guidelines	Required Quantity¹
Coax Tool Kit	1786-CTK	Use the tool kit to create your trunk cable to your specifications.	One

¹ You will need to double your quantities when ordering components for a redundant cable system.

² The connector kit may be shipped with two ferrules. The smaller diameter ferrule should not be used with ControlNet Ex applications.

What Is Next?

After you gather all of the parts for your ControlNet Ex media system, you are ready to go to Chapter 3 to begin the installation of your network.

Install a ControlNet Ex Media System

What This Chapter Contains Follow the instructions in this chapter to install your ControlNet Ex media system.

For	See Page
Install the Trunk Cable	3-1
Mount the Taps	3-2
Specifications	3-6
Install Fiber Hubs	3-6
Install Cable Connectors	3-13
Connect Cable Sections	3-25
Terminate Segments	3-25
Connect Devices	3-27
Install the 1797-BCNR Module	3-28

TIP

You should read Chapter 2, Plan a ControlNet Ex Network, before you install your network.

Install the Trunk Cable

When installing your trunk cable, observe your cable supplier's installation instructions and these guidelines.

Wire External to Enclosures

When the RG-6 type coax cable is being pulled through multiple conduit bends, follow these specifications.

For This Coax Cable	The Pull Strength Should Not Exceed	The Bend Radius Should Not Exceed
PVC	42.75 kg (95 lbs)	76.2 mm (3.0 in.)

Wire Inside Enclosures

When the RG-6 type coax cable is not being pulled through conduit, follow these specifications.

For This Coax Cable	The Bend Radius Should Not Exceed
PVC	38.1 mm (1.5 in.)
Tap drop-cable	25.4 mm (1.0 in.)

The 1797-EXMK Cable Marking kit is available for clearly marking drop cables and trunk cables as intrinsically-safe.

Mount the Taps

First select where you want to mount the taps, then use this mounting procedure.

Select Where to Mount the Taps

There is no spacing requirement between taps; you can install two adjacent taps if necessary by using a barrel connector (1786-BNCP).

IMPORTANT

If the barrel connector (1786-BNCP) is used, use an intrinsically-safe insulator, the light-blue dust caps we provide, or tape having a 500V insulation rating to cover exposed metal parts. Local agencies require their use for intrinsically-safe certification.

Be certain that:

- you choose a convenient location to mount and route the cable.
- the location does not cause any cable bend-radii to exceed the limits listed on pages 3-1 and 3-2.
- you route the cable in accordance with intrinsically-safe cable routing specifications.
- you do not mount the tap in a position that routes the drop cable over any ac power terminals on nearby modules.

ATTENTION

Do not allow any metal portions of the tap, such as the universal mounting bracket screws or connectors, to contact any conductive material. This contact could cause noise on the network.

Also be certain all exposed metal is covered by either the intrinsically-safe insulators or tape having a 500V dielectric rating.

Mount the Taps

You can mount your ControlNet Ex taps (Y-tap and T-tap):

- to a universal mounting bracket, and then mount the tap and bracket as an assembly.
- through the body holes in the tap using screws, flat washers, and a tie wrap.

Once you have mounted your taps, you can store or discard any unused universal mounting brackets.

TIP

See Appendix A for universal mounting bracket and tap mounting dimensions.

Mount a Tap with a Universal Mounting Bracket

1. Align the universal mounting bracket with the mounting holes on the tap.
2. Use the screws provided with the tap to attach the tap to the universal mounting bracket.

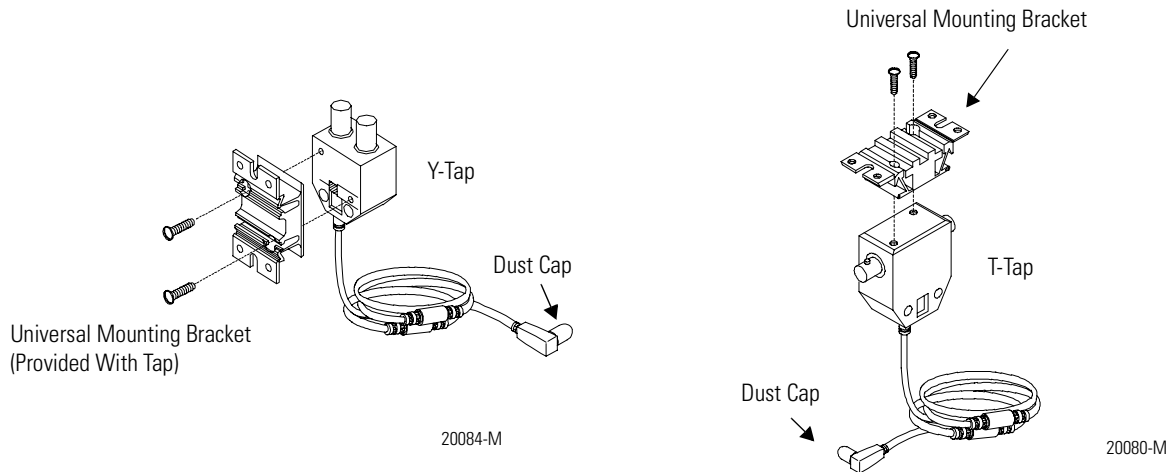

Use only the screws that are packaged with the tap. They are the proper length and head style.

ATTENTION



Do not over-tighten the screws. Over-tightening the screws can damage the tap. The applied torque should be 0.2-0.4 Nm (1-2 ft-lbs).

ATTENTION



Do not remove the intrinsically-safe dust cap unless the tap drop is connected to a ControlNet Ex product.

3. Mount the tap and bracket assembly to a DIN rail or another mounting surface.

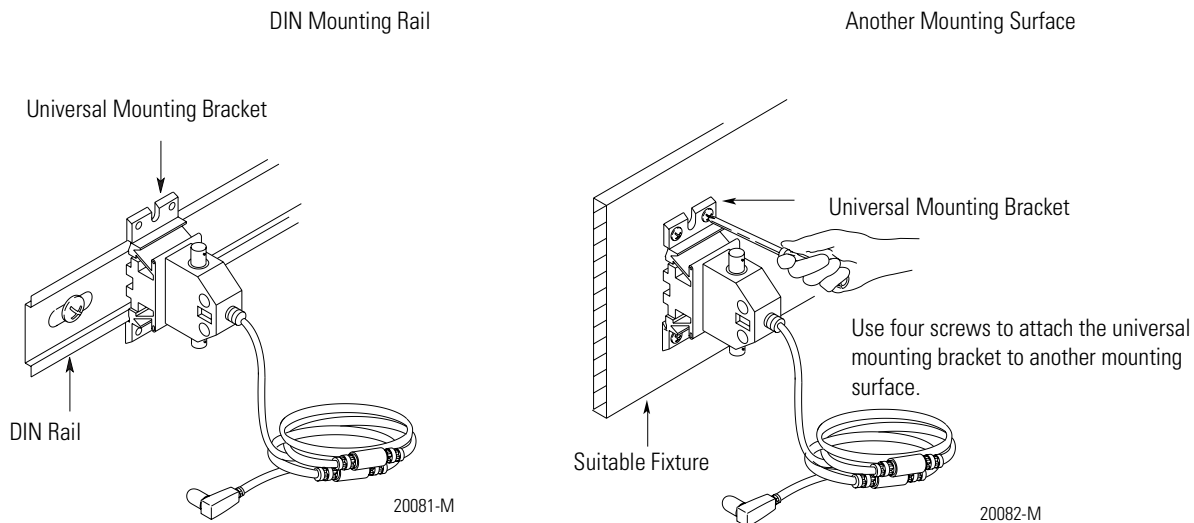

Mount the universal mounting bracket on specified Allen-Bradley mounting rails or #3 style symmetrical DIN rails (35 mm X 7.5 mm [1.38 in. x 0.30 in.])

Type of Rail	Cat. No.	Type of Rail	Cat. No.
A-B rail	1492-N1	DIN rail #3	199-DR1
	1492-N22		1492-DR5
	1492-N44		1492-DR6
	1492-DR7		

ATTENTION



Use an intrinsically-safe insulator, the light-blue dust caps we provide, or tape having a 500V insulation rating to cover exposed metal parts. Local agencies require their use for intrinsically-safe certification.

Mount a Tap Through the Body Holes

TIP

A suitable fixture (mounting surface) can be conductive or grounded because the mounting holes are electrically isolated.

Mount the tap to a suitable fixture by using a tie wrap, or screws and flat washers.

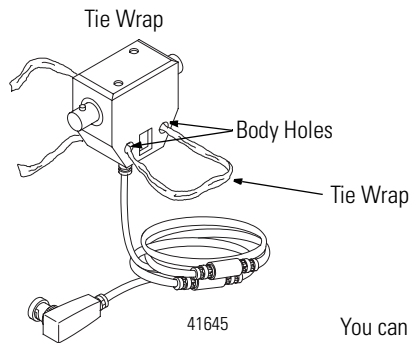

You can use a variety of screw types.

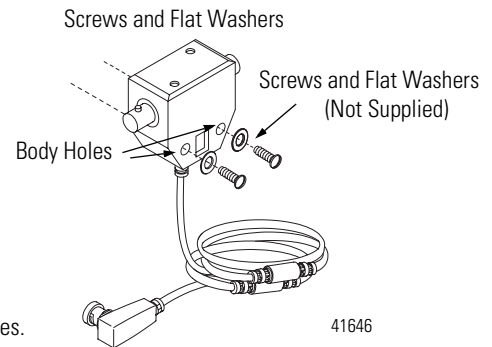

ATTENTION



Do not over-tighten the screws. Over-tightening the screws can damage the tap. The applied torque should be 0.2-0.4 Nm (1-2 ft-lbs). Do not use screws larger than #8 in these holes.

Specifications

The following table lists the specifications for the ControlNet Ex taps.

Operating temperature	-20 to 70 °C (-4 to 158 °F)
Storage temperature	-40 to 85 °C (-40 to 185 °F)
Relative humidity	5 to 95% noncondensing

Install Fiber Hubs

Read the following sections before installing a fiber repeater hub.

To Install a Fiber Repeater Hub, You Should	See Page
Apply the Installation in Zone 1 and related intrinsically-safe warnings and standards	3-7
Select where to mount the fiber repeater hub	3-8
Mount the fiber repeater hub	3-9

Installation in Zone 1

The 1797-RPA and 1797-RPFM modules must not be exposed to the environment. You must install these modules in a metal enclosure. This repeater hub has a protection factor of IP20.

ATTENTION



These modules cannot be used in a hazardous environment after they have been exposed to non-intrinsically-safe signals.

Electrostatic Charge

Attention: Avoid electrostatic charge.

Protect the system against electrostatic charge. Post a sign near this module. The sign should read

Attention! Avoid electrostatic charge.

For your convenience, see page C-1 for signs that you can cut out.

European Community Directive Compliance

If this product has the CE mark it is approved for installation within the European Community or EEA regions. It has been designed and tested to meet the following directives.

EMC Directive

This product is tested to meet the Council Directive 89/336/EC Electromagnetic Compatibility (EMC) by applying the following standards, in whole or in part, documented in a technical construction file:

- EN50081-2 EMC — Generic Emission Standard, Part 2 — Industrial Environment
- EN50082-2 EMC — Generic Immunity Standard, Part 2 — Industrial Environment

This product is intended for use in an industrial environment.

Ex Directive

This product is tested to meet the Council Directive 94/9 EC (ATEX 100a) Equipment and Protective Systems Intended for Use in Potentially Explosive Atmospheres by applying the following standards:

- EN50014:1992, Electrical Apparatus for Potentially Explosive Atmospheres
- EN50020:1994, Electrical Apparatus for Potentially Explosive Atmospheres - Intrinsic Safety “i”
- EN50039:1980, Electrical Apparatus for Potentially Explosive Atmospheres - Intrinsically-safe Electrical Systems “i”
- pr EN50284:1997, Special requirements for construction, test, and marking of electrical apparatus of equipment group II, category 1 G

Inputs/Outputs

Do not apply any non-intrinsically-safe signals to the fiber modules.

When you use an intrinsically-safe electrical apparatus according to EN50020, the European directives and regulations must be followed.

Select a Fiber Repeater Hub Mounting Location

The fiber repeater hub should be mounted:

- so that air can flow in and out of the air holes on the top and bottom of the coax repeater.

For proper ventilation, be certain that there is a minimum of 5.1 cm (2 in.) from surrounding equipment.

- in a NEMA enclosure to provide protection from dust, moisture, or corrosive atmospheres to a grounded metal plate, if possible.

ATTENTION

Be certain that the adapter and fiber modules are secured together with DIN-rail anchors. Failure to do so may result in the loss of communications or cause damage to the modules.

Mount the Fiber Repeater Hub

Follow this procedure to mount the fiber repeater hub.

1. Position the module on a 35 mm x 7.5 mm (1.38 in. x 0.30 in.) DIN rail (A-B part number 199-DR1) at approximately a 30° angle.

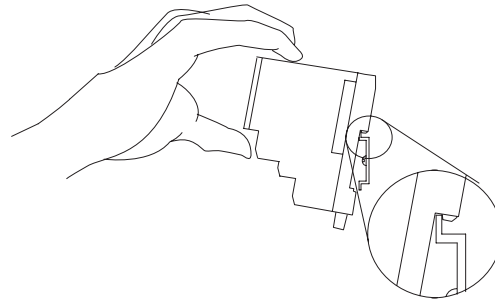

41167

2. Hook the lip on the rear of the adapter onto the top of the DIN rail, and rotate the module onto the rail.

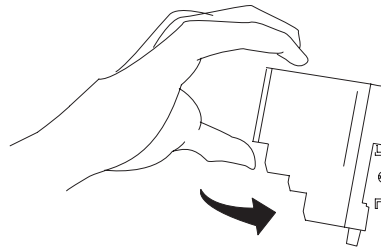

41166

3. Press the adapter down onto the DIN rail until flush.

The locking tab should snap into position and lock the module to the DIN rail.

4. If the adapter does not snap into position, use a screwdriver or similar device to move the locking tab down while pressing the module flush onto the DIN rail. Release the locking tab to lock the module in place. If necessary, push up on the locking tab to lock.

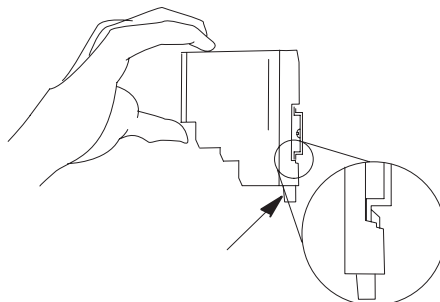

41168

5. Remove the adapter backplane connector cover.
6. Follow steps 1 through 4 to attach fiber modules to the DIN rail.
7. Once attached to the DIN rail, slide fiber modules to the left to mate with the adapter.

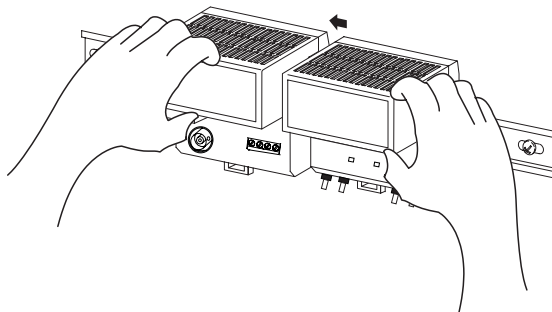

41169

IMPORTANT

A DIN-rail end anchor (A-B part number 1492-EA35) must be used on the left side of the adapter and to the right side of the fiber module to keep the units from moving.

8. Be certain the last fiber module has its backplane connector cover in place.
 9. Connect the adapter wiring as shown on page 3-11.
-

IMPORTANT

You can attach only two media modules to the repeater adapter. If you exceed the module limit, you may cause damage to the adapter or fiber modules and void the intrinsically-safe certification.

Connect the Fiber Repeater Hub to a ControlNet Ex Network

1. Connect to the ControlNet Ex coax network with the drop line of the Ex coax tap to the adapter BNC connector.

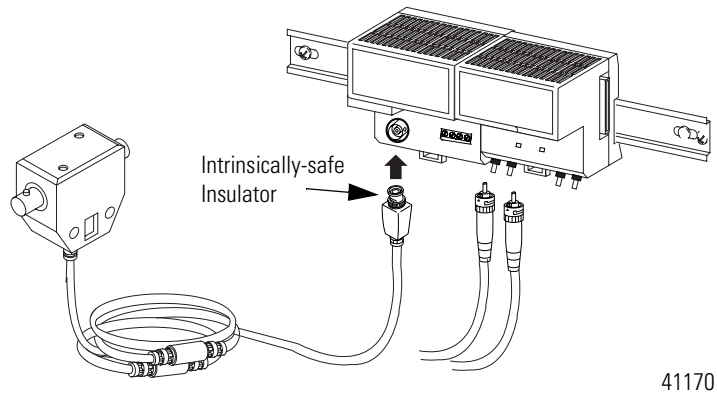

2. Connect the fiber media to the fiber module by attaching the receive and transmit fibers to either the left or right set of receive and transmit ports.

IMPORTANT

Make note of which fiber is receive and which is transmit. These fibers must be interchanged at the opposite end of the cable.

3. Attach the opposite ends of the cable to the other fiber module.

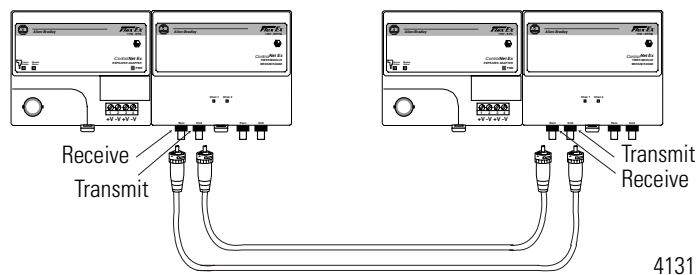

ATTENTION

Use the blue intrinsically-safe insulators on all coax BNC drop connectors as they are installed.



4. Apply +V and -V power from a 1797 power supply to the adapter through a removable terminal block.

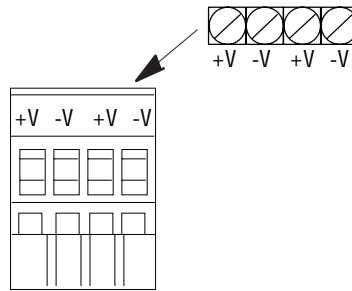

41297

Screw terminals and spring terminals are provided.

5. Strip the +V and -V wires to a length so that no bare conductor shows after inserting the wires into position.
6. If you are using the spring terminals of the plug, insert a screwdriver into the slot and carefully pry until the spring clamp opens to accept the wire.

ATTENTION



Do not use any unused terminals on this adapter. Using these terminals as supporting terminals can result in damage to the module or unintended operation of your system.

Make certain that you power this adapter with an intrinsically-safe power supply. Do not exceed the values listed in the specifications for this adapter.

Do not remove or replace a module when power is applied. Interruption of the bus can result in unintended operation or machine motion.

IMPORTANT

Be certain that all fiber modules are attached and secured before you apply intrinsically-safe power to the adapter. Failure to do so may cause damage to the adapter and modules.

Install Cable Connectors

After you have mounted the taps, you need to attach cable connectors to the ends of your trunk cable sections.

Collect Your Tools

To install the cable connectors, we recommend that you use the tools in the ControlNet Coax Toolkit, catalog number 1786-CTK.

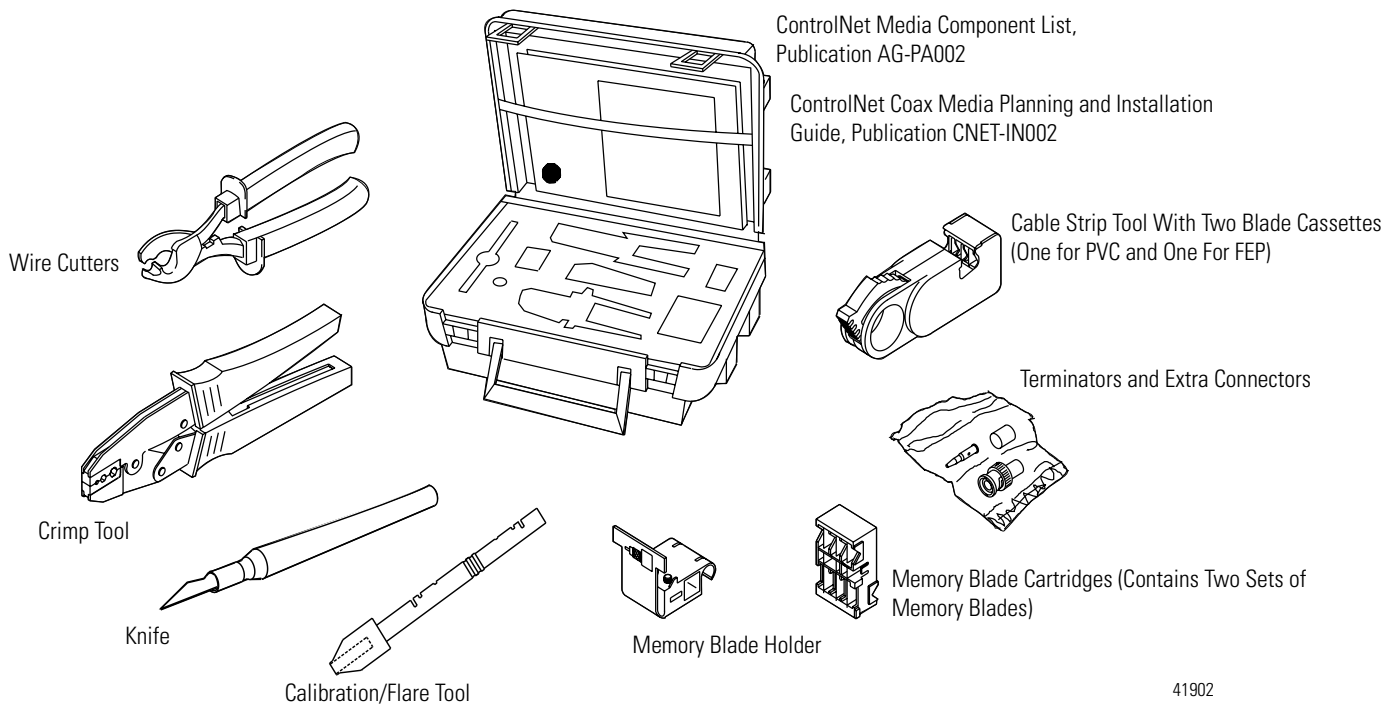

ATTENTION



Be certain that you calibrate the cable strip tool the first time you use the tool and every time you change the blade for both memory cartridges. Refer to Appendix B for the proper calibration procedure. Due to slight differences between coax cables, you should calibrate the tool when changing:

- part numbers
- from one cable manufacturer to another

Strip the Cable

When you cut cable sections, make them long enough to route from one tap to the next with sufficient length so that the bend radius is not less than:

- 76.2 mm (3 in.) for wiring external to enclosures
- 38.1 mm (1.5 in.) for wiring inside enclosures

ATTENTION



Be certain to perform the calibration procedure the first time you use the tool and every time you change the blade or both memory cartridges. Refer to Appendix B for the proper calibration procedure.

1. Verify that you have the proper memory blade holder installed for the type of cable you are using (PVC-CL2 or FEP-CL2P). If you need to change the memory blade holder, see Appendix B.

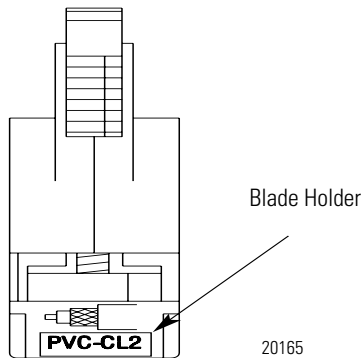

2. Straighten out the end of the cable.
3. Insert the cable into the cable strip tool's cutting chamber so that extra cable, approximately 25.4 mm (1 in.), extends beyond the edge of the tool.

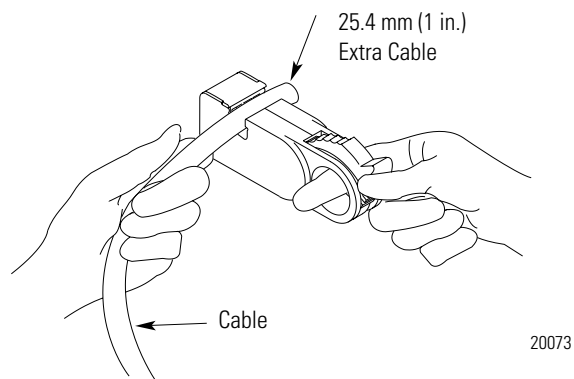

4. Lock the cable into place by moving the chamber-gauge ring forward until it meets the cable with slight resistance.

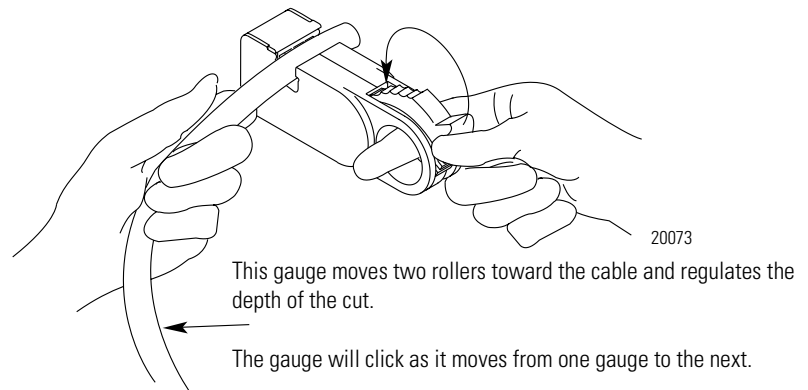

5. Hold the cable in one hand, place the index finger of your other hand inside the chamber-gauge ring and turn the strip tool 360° around the cable. Turn four or five full rotations until the strip tool glides easily around the cable.

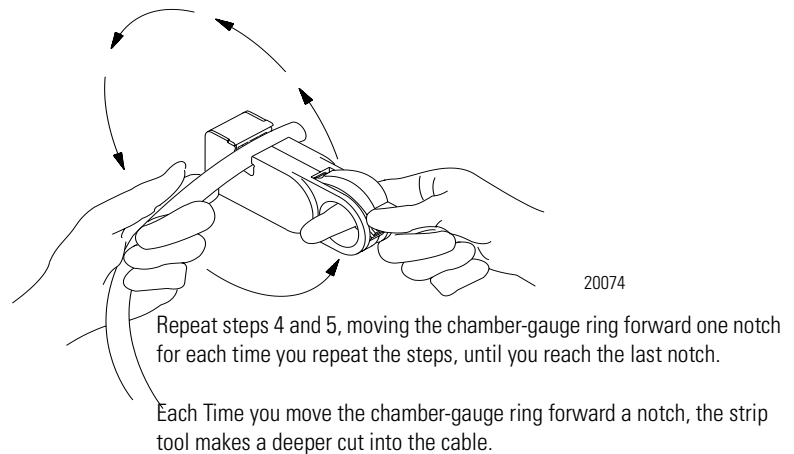

IMPORTANT

The last time you repeat steps 4 and 5, apply sufficient pressure on the chamber-gauge ring to be certain the ring has reached the last stage. The chamber gauge reads 'stop' for the last repetition.

6. After you have moved the chamber gauge ring to the last position and turned the strip tool the final time:
 - a. Move the chamber-gauge ring backward to release the strip tool and remove it from the cable.
 - b. Slip the crimp ferrule onto the cable. Push it back to the sheath area of the cable to keep it out of the way for the moment.

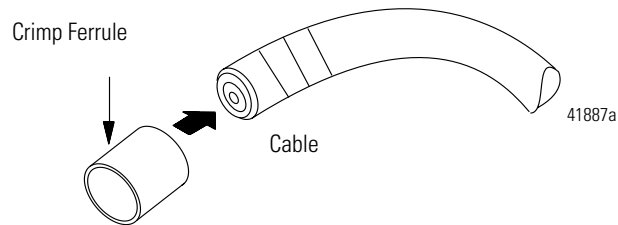

- c. Strip away the appropriate portion of the cable without using the strip tool.
- d. Clean the cable parts that remain from the strip chamber after each use.

Be sure to strip the cable to expose these layers of the cable:

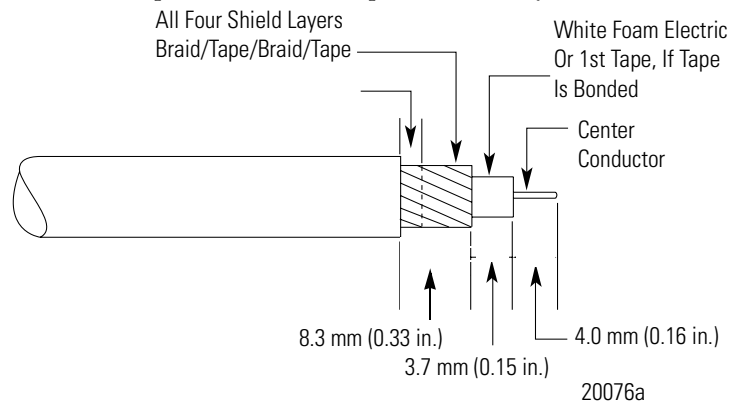

Be sure to strip the cable to expose these layers of the cable:

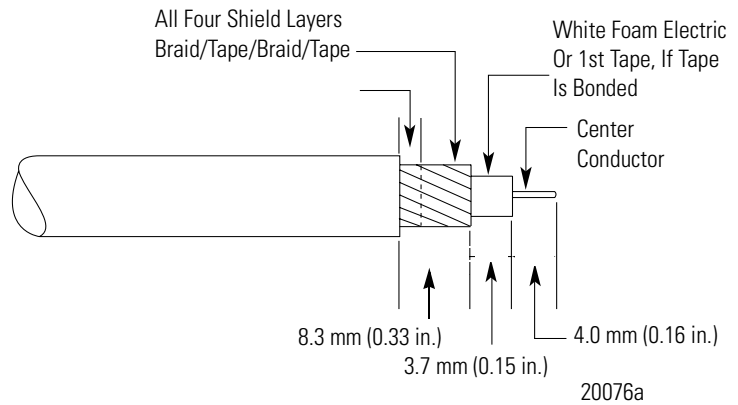

IMPORTANT

If you do not see the three distinct layers of cable or if the outer braid has been scored or cut, snip off the exposed end with the wire cutters and repeat the entire cable-stripping process. It is very important that the outer braid be intact before you crimp the connector.

If You Are Using	Go To Step
FEP cable	7
PVC cable	8

- If you are using plenum FEP cable, cut off an additional 3.1mm (approximately 1/8 in.) of the outer sheath with the knife from the toolkit.

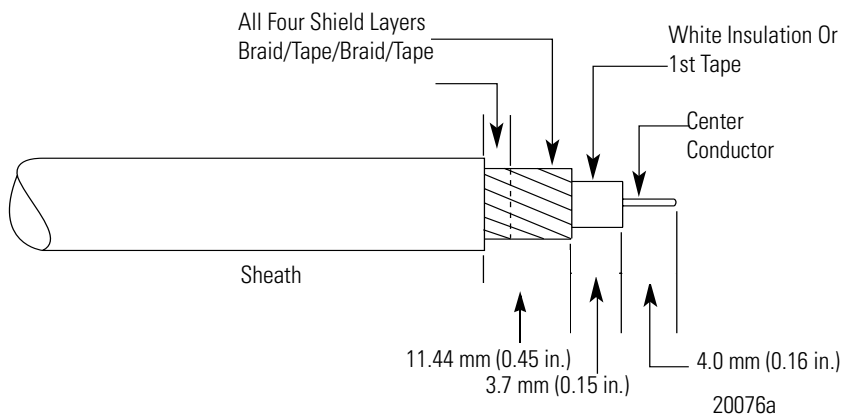

- Be certain that the center conductor measures 4.0 mm (0.16 in.) in length.

Use the imprint guide on the back of the ControlNet tap or the calibration tool to verify this.

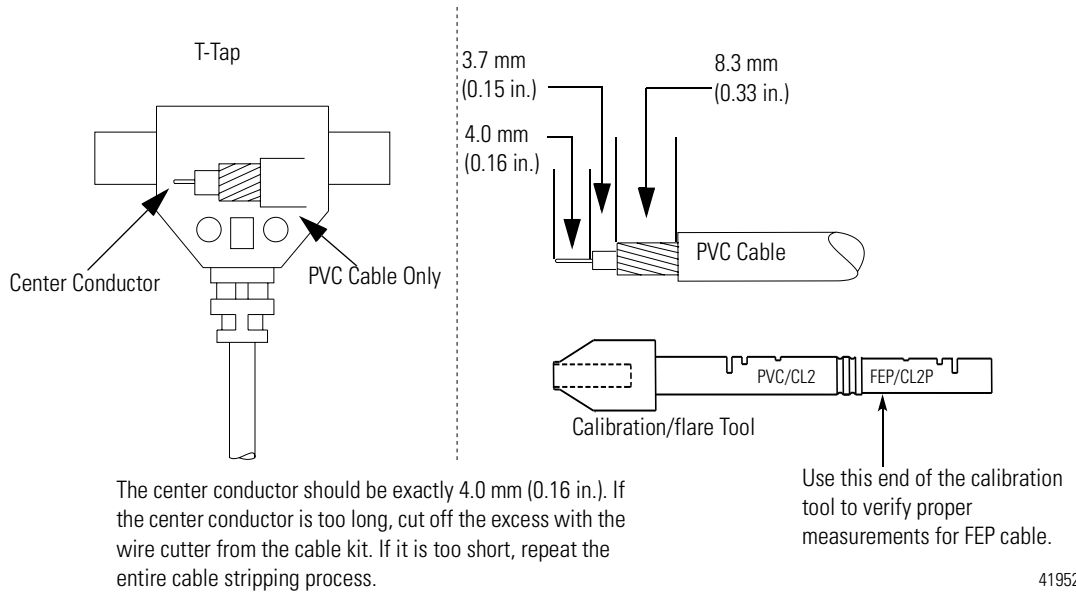

41952

ATTENTION



Check for any braid stranding that may not have been cut at the proper length. If one strand comes in contact with the center conductor, it could short out the cable. If you find any such strands, cut them to the correct length.

ATTENTION



Check the outer braid of cable for cut or scored braid wire after you strip the cable. If the braid is damaged, cut off the end and strip the cable again. You may need to adjust the appropriate stripper blade by backing the set screw out 1/8 of a turn. Do not crimp the BNC to a damaged braid. This type of mistake accounts for most of the connectivity problems that can occur. Precise, clean connections will reduce network errors.

Test for Electrical Shorts and Continuity Between the Center Conductor and the Shield

1. The NetLinx Media Checker (catalog number 1788-MCHKR) is the preferred tool for continuity testing. Attach the connector end of the cable to the port on top of the media checker.

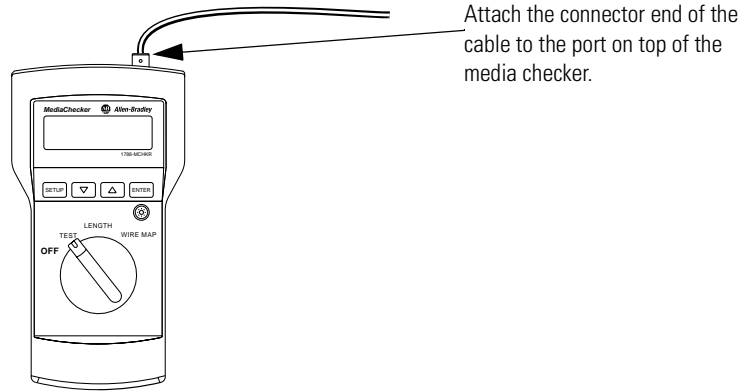

31195-M

2. As a secondary method, you can also use an ohmmeter or continuity tester to test for a short between the connector body and pin.
3. Use shorting clips to connect a temporary short between the pin and connector body at one end of the cable.

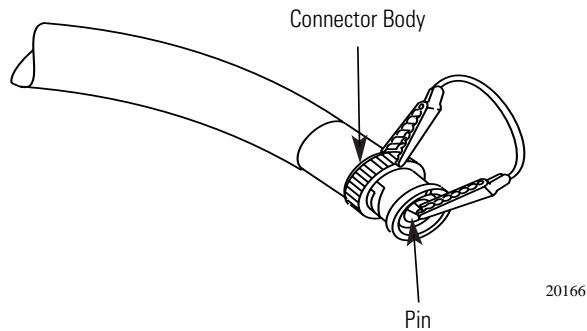

4. At the other end of the cable, use the media checker, an ohmmeter, or continuity tester to test for electrical continuity.

If Resistance Reading Indicates	Then
That a short exists	Continue to next section
There is no short	Use your wire cutters to cut off the connector, install a new connector and begin testing again

IMPORTANT

Replace the trunk cable section if problems persist with the cable after completing these tests.

Attach the Connectors to the Cable

1. Push the calibration/flare tool onto the cable and with a slight twisting motion (with sufficient inward pressure) to expand the braid.

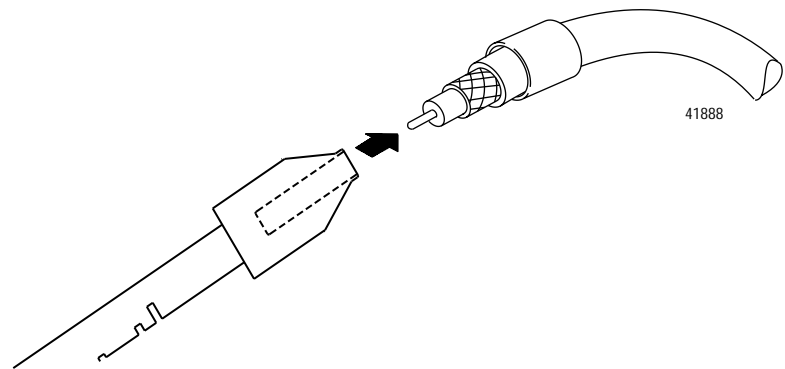

Push the calibration/flare tool gently and rotate slightly onto the connector while you apply pressure. This will work the base of the connector underneath the wire braid slowly.

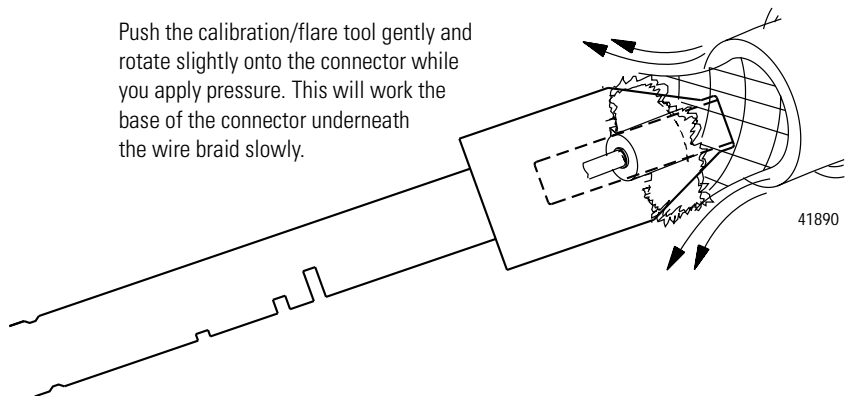

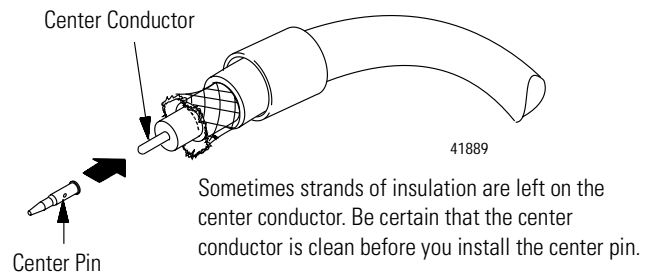
2. Place the center pin over the center conductor.**IMPORTANT**

Be certain that the center pin slips onto the center conductor completely. The back shoulder of the center pin should be up against the white insulation. If it is not, recheck the length of the center conductor.

3. With the center pin in place, use the crimp tool to crimp the pin into place.

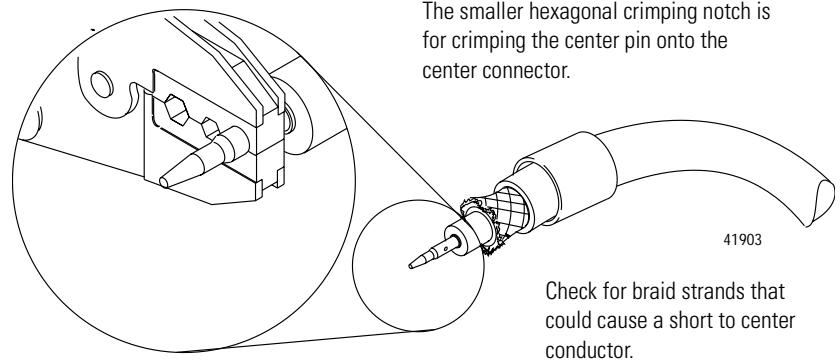

4. Slide the ControlNet connector onto the cable.

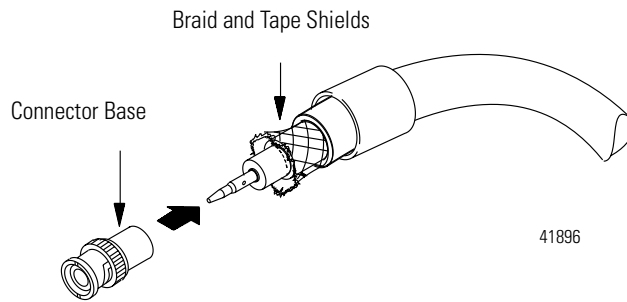

5. Slide the crimp ferrule over the three outer shields and connector base until it meets the shoulder on the connector.

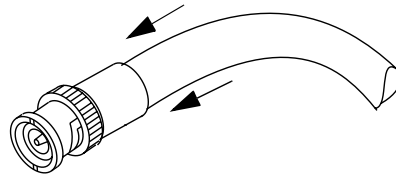

20077e

6. Use the crimp tool to crimp the ferrule. Position the crimp tool on the ferrule as close as possible to where the connector base and ferrule meet. Press the tool tightly around the ferrule until the crimp tool releases.

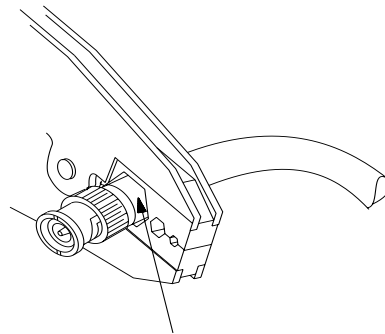

Crimp Ferrule

The larger hexagonal crimping notch is for crimping the ferrule which holds the connector to the cable.

IMPORTANT

Many network problems are due to improperly installed connectors. Your connectors should fit tight on the ends of all your cables. Pull the connector to verify that it is attached. If it is loose or comes off, snip off the connector and install a new one. The connector should withstand a minimum 75lbs pull force if properly installed.

Test for Electrical Shorts and Continuity Between the Connector Body and Pin

1. Use an ohmmeter or continuity tester to test for a short between the connector body and pin.

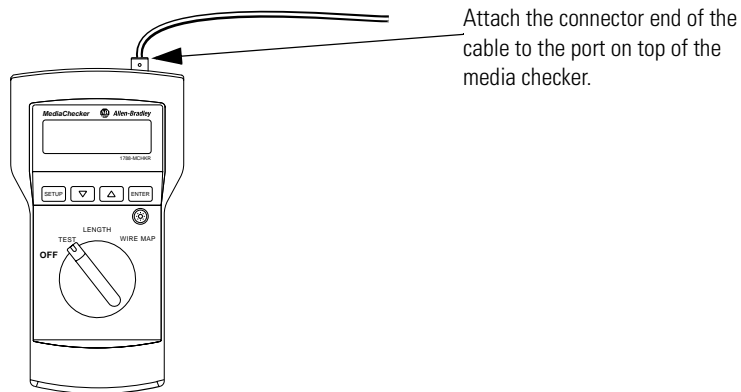

31195-M

If Resistance Reading Indicates	Then
That a short exists	Continue to next section.
There is no short	Use your wire cutters to cut off the connector, install a new connector, and begin testing again.

2. Connect a temporary short between the pin and connector body at the opposite end of the cable.

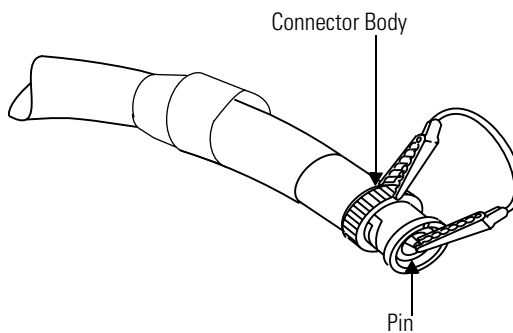

41686

- At the same end of the cable tested in step 1, use an ohmmeter or continuity tester to test for electrical continuity.

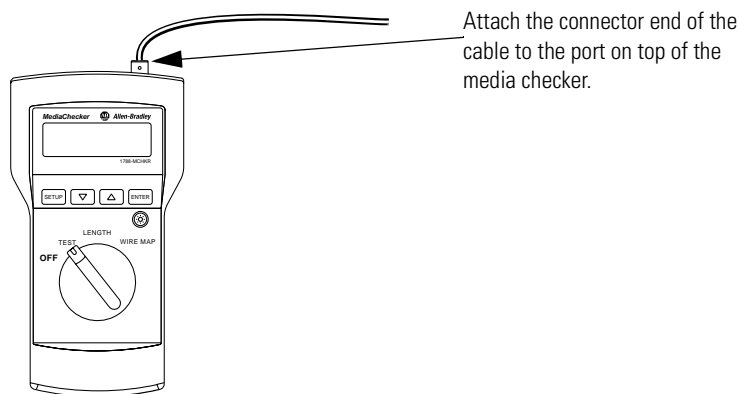

31195-M

If Resistance Reading Indicates	Then
That a short exists	Continue to next section.
There is no short	Use your wire cutters to cut off the connector, install a new connector, and begin testing again.

Connect Cable Sections

Connect the cable sections to the tap's BNC connectors and cover all exposed metal with intrinsically-safe insulators.

Terminate Segments

The taps on the ends of the segment have only one cable connector attached to them. This leaves an open, or unterminated, end on the segment. Signals transmitted along the cable will reflect off these unterminated ends and interfere with transmission.

To eliminate signal reflections from the ends of the segment, you must attach a 75 Ω trunk terminator (catalog number 1797-XT) to the first and last taps on the segment. The terms first and last refer to the physical location of the node along the trunk cable.

1. Connect one end of the trunk cable section to one of the tap BNC connectors.

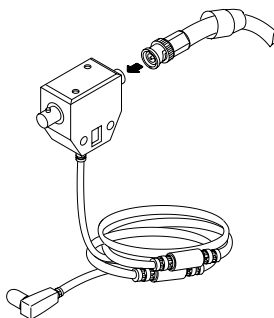

20078

2. Slide the intrinsically-safe blue insulator over the BNC connector to cover any exposed metal.

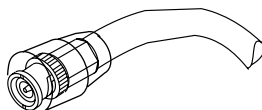

3. Install a 75Ω terminator onto the tap's other BNC connector.

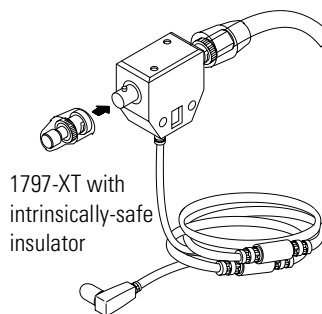

Repeat steps 1 and 2 at the other end of the segment.

1797-XT with intrinsically-safe insulator

20079

ATTENTION

Be certain that the intrinsically-safe insulator covers all metal parts.



Connect Devices

After you terminate your segments, connect your devices.

To Connect a	See
Fiber repeater hub	Page 3-11
ControlNet Ex adapter	Procedure below

1. Remove and save the blue dust cap (on the straight or right-angle connector).
2. Replace the dust cap with the blue intrinsically-safe insulator ring.
3. Connect the straight or right-angle connector to your device.

If Your Node Supports	Connect the Straight or Right-angle Connector
non-redundant media	To the channel A connector on the device (channel B is not used) ¹
redundant media	From trunk cable A to channel A on your device From trunk cable B to channel B on your device

¹ While both channels are active, we recommend using channel A for non-redundant media.

Install the 1797-BCNR Module

You can also use the 1797-BCNR FLEX Ex Redundant ControlNet Barrier Module to interconnect between ControlNet coax and ControlNet Ex networks. This module provides an alternative to installing ControlNet coax and Ex fiber repeater modules.

Use the 1797-BCNR FLEX Ex ControlNet barrier module in Class I, Division 2 or Zone 2 safe areas, as shown in the figure.

Figure 3.1 ControlNet Coax to Ex System With 1797-BCNR FLEX Ex ControlNet Barrier Module

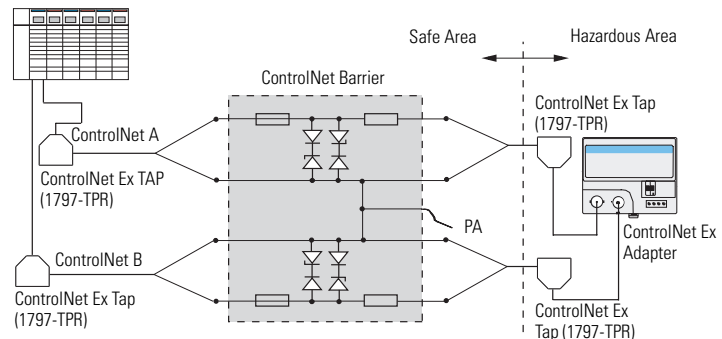

WARNING



The 1797-BCNR barrier module cannot be used in an intrinsically-safe environment after it has been exposed to non-intrinsically-safe signals.

IMPORTANT

For complete installation instructions and requirements, refer to the FLEX Ex Redundant ControlNet Barrier Module Installation Instructions, publication 1797-5.35.

To install the module:

1. Select the appropriate mounting location.
2. Mount the barrier module on Rockwell Automation part number 199-DR1 DIN rail.

3. Ensure the locking tabs snap into place.

IMPORTANT

Connect the ControlNet Ex side of the barrier module to either a 1797-ACNR15 FLEX Ex I/O module or a 1797-TCAP FLEX Ex Safe Tap Dummy Load using only ControlNet Ex Taps (such as 1797-TPR, 1797-TPYR, 1797-TPS, or 1797-TPYS).

4. Remove the insulator boot from the terminals.
5. Connect the trunk cable as shown in the illustration.

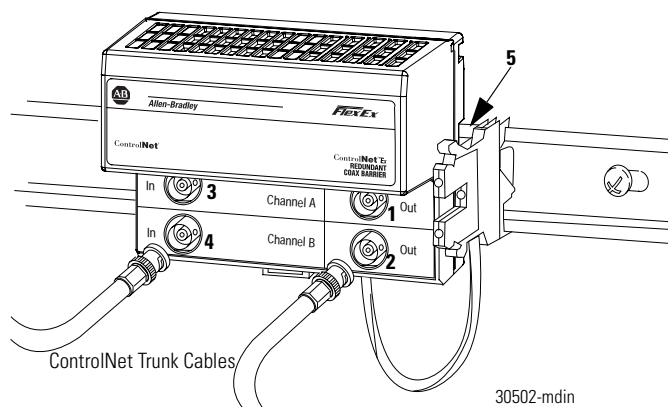

- a. Connect the ControlNet trunk cable to the Channel A output connector (1).
 - b. Connect the redundant ControlNet trunk cable to the Channel B output connector (2).
 - c. Connect the ControlNet trunk cable to the Channel A input connector (3).
 - d. Connect the redundant ControlNet trunk cable to the Channel B input connector (4).
6. Install a direct ground wire with a minimum diameter of 4 mm² between terminal 5 and the PA Ground (Equipotential System) in the hazardous area where the ControlNet Ex coax cable is installed.

IMPORTANT

Do not connect terminal 5 or the DIN rail to a standard earth ground connection in the safe area.

Notes:

Mounting Dimensions

What This Appendix Contains

Use these mounting dimensions to mount your taps, universal mounting brackets, and repeaters.

Tap Placement

Make copies of these templates as necessary to help you mark placement for your taps.

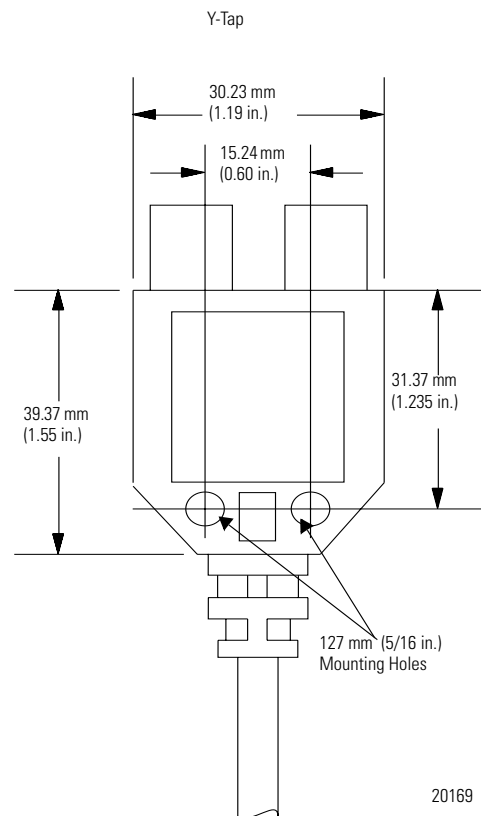
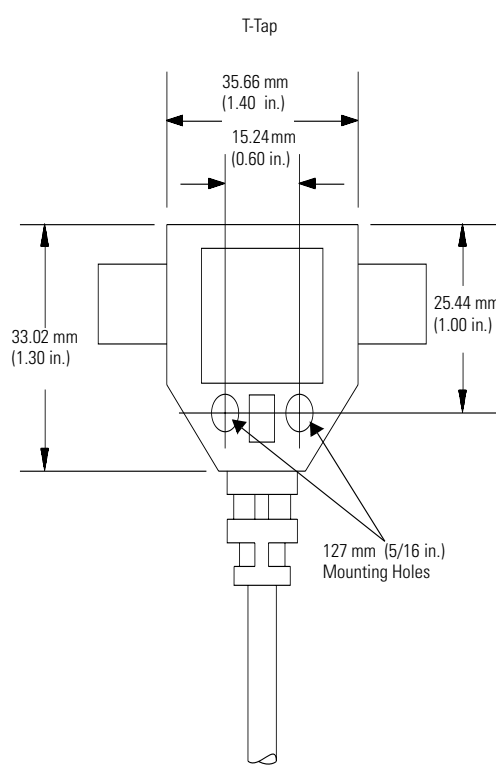

Universal Mounting Bracket

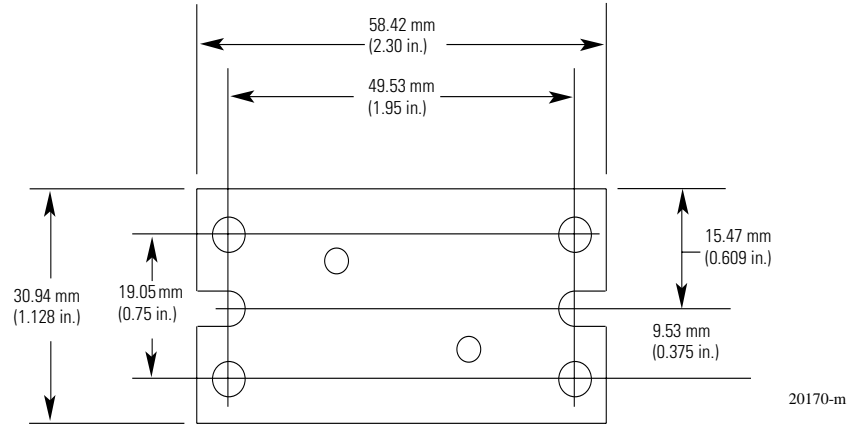

Adjust the Cable Strip Tool

What This Appendix Contains

Follow the instructions in this appendix to calibrate the cable strip tool supplied with the ControlNet Coax Toolkit (1786-CTK).

Calibrate the Cutting Blades

Use the following procedure to calibrate your cable strip tool to cut FEP or PVC cable.

1. Turn the three screws outward to back the blades out. This prevents the calibration tool from bottoming out.
2. Place the calibration tool into the cable strip tool with the narrow end installed and facing forward for FEP cable (use the wider end for PVC).

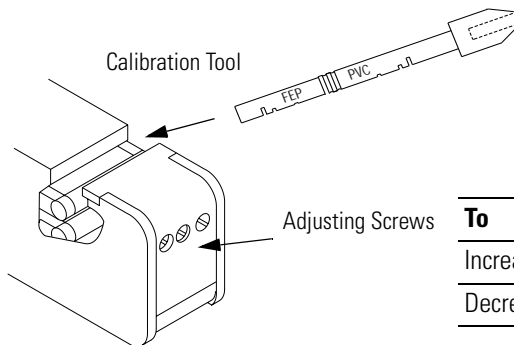

To	Turn The Screw
Increase the cut depth	Clockwise
Decrease the cut depth	Counterclockwise

2088-m

3. Tighten the chamber gauge ring so that the calibration tool is locked in place.
4. Continue tightening all the way to the chamber gauge stop.

When aligned properly, the grooves of the calibration tool should align with the blades.

5. Adjust the screws of the memory clip so that the blades just touch the calibration tool.

ATTENTION



Do not over-tighten the screws of the cable strip tool. The blades should not bend, shift, or penetrate the calibration tool.

6. Retract the handle of the cable strip tool.
7. Remove the calibration tool from the cable strip tool.

When you have finished, the blade should make a cut of the following dimensions in your cable.

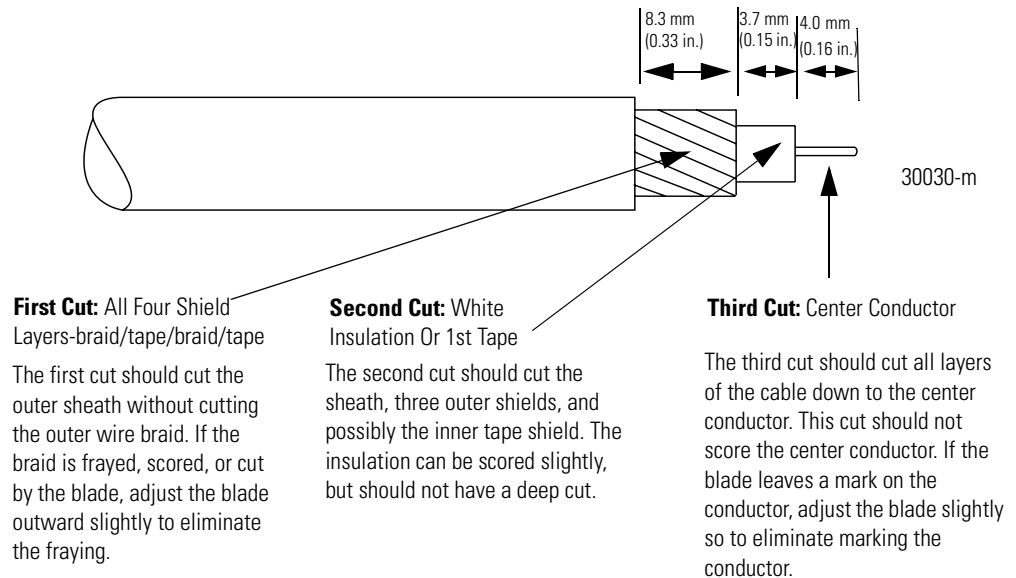

The first and second cut adjustments need to be precise. Adjustments as small as 1/12 to 1/8 of a turn can make the difference between a perfect and an imperfect cut.

ATTENTION



Check the outer braid of cable for cut or scored braid wire after stripping the cable. If the braid is damaged, strip the cable again. If needed, adjust the appropriate stripper blade by backing the set screw out 1/8 of a turn. Do not crimp the BNC to a damaged braid. This type of mistake accounts for most of the connectivity problems that occur. Precise, clean connections will reduce network errors.

Reverse and Replace the Cutting Blades

To reverse or change the cutting blades:

1. Use a screwdriver to lift the memory blade holder and swing it back.

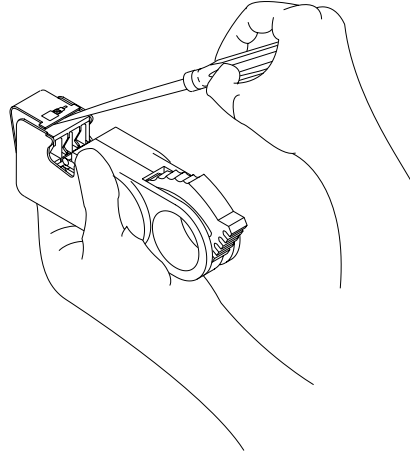

20182-m

2. Slide the memory blade cartridge out of the strip tool.

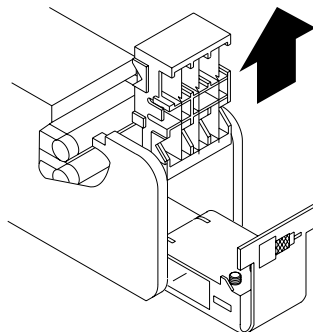

20183-m

If You Are	Go To
Reversing the memory blade cartridge to use the second set of blades	The next step
Replacing the memory blade cartridge	Step 4

3. Flip the memory blade cartridge and slide it back into the strip tool.

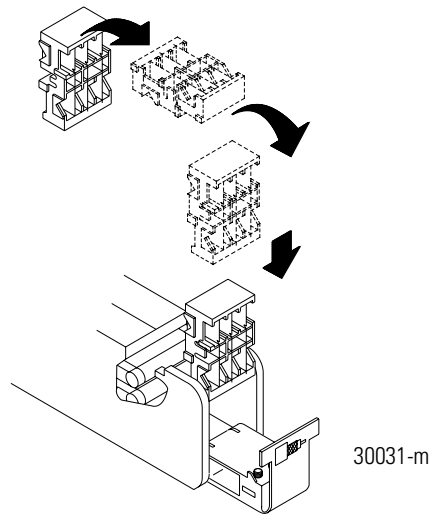

Go to step 5.

4. Align the memory blade cartridge (the side with the raised notches) to the raised area on the inside of the strip tool and slide the new memory blade cartridge in.

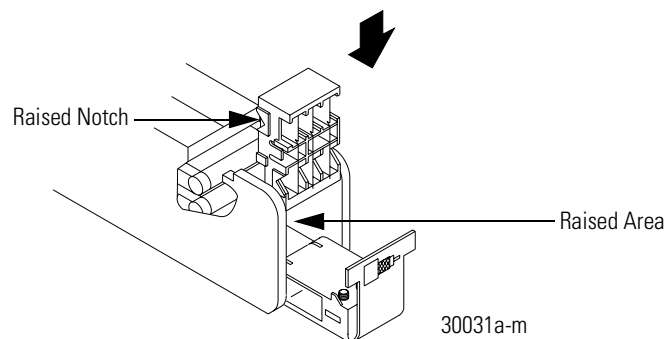

TIP The blades should be on top as you slide the cartridge in.

5. Swing the memory blade holder closed.

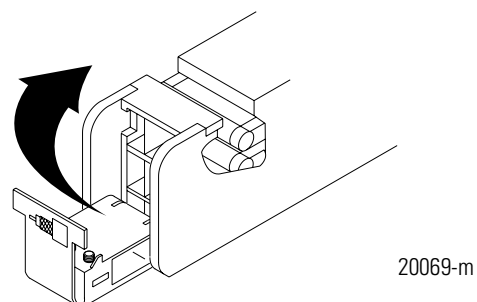

Change the Memory Blade Holder

You received two memory blade holders with your cable strip tool; one is for PVC-CL2 cable, and the other is for plenum FEP-CL2P cable. You need to install the appropriate memory blade holder for the type of cable you are stripping (PVC or FEP).

1. Lift the latches on the memory blade holder and swing it back.

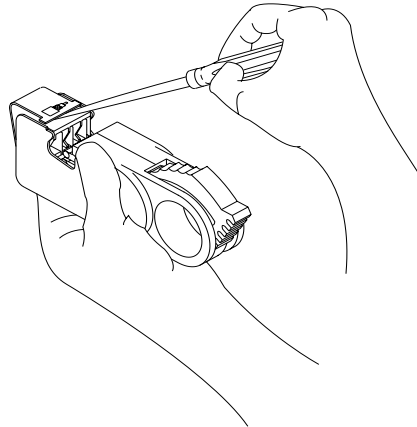

20182-m

2. Snap the memory blade holder off the rod and remove it from the strip tool.

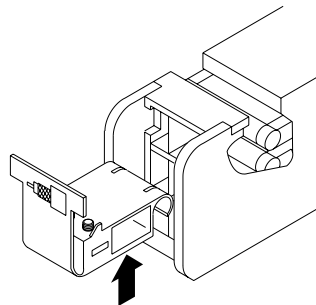

20070-m

3. Position the appropriate memory blade holder on the rod and snap the holder into place.

4. Swing the memory blade holder closed.

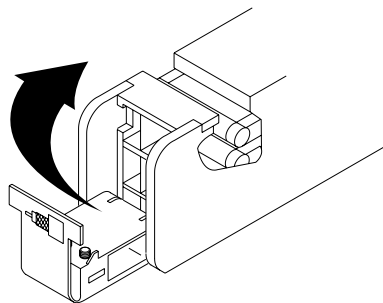

20069-m

Notes:

Protect Your System Against Electrostatic Discharge

Protect the system against electrostatic charge. Post a sign near this module: Attention: Avoid electrostatic charge. For your convenience, we provide some signs you can cut out below.

Post these labels or something similar beside each module to protect the system against electrostatic charge.

Attention: Avoid electrostatic charge.

Attention: Avoid electrostatic charge.

Attention: Avoid electrostatic charge.

Attention: Avoid electrostatic charge.

Notes:

A

abbreviations and symbols 1-2
about this manual 1-1
application considerations 2-13

B

barrel connector 2-8
BNC cable connectors 1-6, 2-8
installing 3-13
bridge 1-2
bullet connector 2-2, 2-8

C

cable connectors 1-6, 2-8
barrel 2-8
bullet 2-8
installing 3-13
isolated bulkhead 2-8
right-angle 2-8
categories of conductors 2-13
coax cable 2-3
Collect Your Tools 3-13
continuity tester 3-19
ControlNet cable system
application considerations 2-13
cable connector
bullet 2-2
cable connectors 1-6, 2-8
optional 1-6
Coax Toolkit 3-13
component definitions 1-2
connecting cable sections 3-25
connecting devices 3-27
determine
cable needed 2-3
number of repeaters 2-8
number of taps 2-2
number of terminators needed 2-7
trunk cable section lengths 2-4
type of cable connectors needed
2-8
ferrite beads 2-15
installing
cable connectors 3-13
trunk cable 3-1
link 2-17
mounting taps 3-2
network 1-2
node 1-4
ordering components 2-17
planning guidelines 2-17

redundant media 2-10
repeater 1-2, 1-7, 2-8
segment 1-7, 2-17
stripping trunk cable 3-14
surge suppression 2-15
tap 1-2, 1-4, 2-2, 2-18
mounting dimensions A-1
terminating segments 3-25
terminator 2-18
terminators 1-3, 2-7
testing for electrical continuity 3-19,
3-24
trunk cable 1-2, 1-5, 2-18
testing 3-19, 3-24
wiring 2-14
wiring external to enclosures 2-14
wiring inside enclosures 2-14
trunk cable section 1-2, 1-5, 2-4
wiring guidelines 2-14

ControlNet Coax Toolkit

crimp tool 3-22
knife 3-17
strip gauge 3-18
strip tool 3-14
adjusting the cutting blades B-1
changing the memory blade holder
B-5

crimp tool 3-22**F**

FEP cable 1-2
ferrite beads 2-15
flare tool 3-13

I

installing cable connectors
stripping the cable 3-17
stripping trunk cable 3-14
isolated bulkhead connector 2-8

L

link
planning 2-17

M

media
redundant 2-10
guidelines 2-10
mounting dimensions
tap A-1

N

NetLinx Media Checker 3-19
node 1-4

O

ohmmeter 3-19
ordering components 2-17

P

programming terminals
ways to connect to a ControlNet link 2-3
publications
1770-4.1 2-14
AG-PA002 1-4, 2-8
CNET-IN001 1-1
CNET-IN002 1-1
PVC cable 1-2, 3-1, 3-17

R

redundant media 2-10
guidelines 2-10
repeater 1-2, 1-7, 2-8
selecting where to mount 3-8
RG-6 cable 2-3, 3-1
right-angle connector 2-8

S

segment 1-7
planning 2-17
terminating 3-25
strip tool
adjusting the cutting blades B-1

changing the memory blade holder B-5

support

questions or comments about manual 1-2
technical product assistance 1-2

surge suppression 2-15

T

tap 1-2, 1-4, 2-18
determine number needed 2-2
mounting 3-2
to a universal mounting bracket 3-4
using the body holes 3-6
mounting dimensions A-1
selecting where to mount 3-2
techniques used in the manual 1-2
terminators 1-3, 2-7
trunk cable 1-2, 1-5
bend radius 3-1
installing 3-1
pull strength 3-1
stripping 3-14
terminating 3-25
testing for shorts and continuity 3-19, 3-24
wiring external to enclosures 2-14, 3-1
wiring inside enclosures 2-14, 3-2
trunk cable section 1-2, 1-5, 2-4, 3-25

W**wiring**

external to enclosures 2-14, 3-1
inside enclosures 2-14, 3-2

wiring guidelines 2-14



How Are We Doing?

Your comments on our technical publications will help us serve you better in the future. Thank you for taking the time to provide us feedback.

You can complete this form and mail (or fax) it back to us or email us at RADocumentComments@ra.rockwell.com

Pub. Title/Type ControlNet Ex Media Planning and Installation Manual

Cat. No. 1797-series Pub. No. CNET-IN003A-EN-P Pub. Date January 2006 Part No. 957208-04

Please complete the sections below. Where applicable, rank the feature (1=needs improvement, 2=satisfactory, and 3=outstanding).

Overall Usefulness 1 2 3 	How can we make this publication more useful for you?		
Completeness 1 2 3 (all necessary information is provided)	Can we add more information to help you?		
	procedure/step	illustration	feature
	example	guideline	other
	explanation	definition	
Technical Accuracy 1 2 3 (all provided information is correct)	Can we be more accurate?		
	text	illustration	
Clarity 1 2 3 (all provided information is easy to understand)	How can we make things clearer?		
Other Comments	You can add additional comments on the back of this form.		

Your Name _____
 Your Title/Function _____
 Location/Phone _____

Would you like us to contact you regarding your comments?
 No, there is no need to contact me
 Yes, please call me
 Yes, please email me at _____
 Yes, please contact me via _____

Return this form to: Rockwell Automation Technical Communications, 1 Allen-Bradley Dr., Mayfield Hts., OH 44124-9705
 Fax: 440-646-3525 Email: RADocumentComments@ra.rockwell.com

PLEASE FASTEN HERE (DO NOT STAPLE)

Other Comments

Lined area for writing comments.

PLEASE FOLD HERE

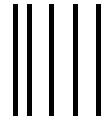

NO POSTAGE
NECESSARY
IF MAILED
IN THE
UNITED STATES

PLEASE REMOVE

BUSINESS REPLY MAIL

FIRST-CLASS MAIL PERMIT NO. 18235 CLEVELAND OH

POSTAGE WILL BE PAID BY THE ADDRESSEE

**Rockwell
Automation**

1 ALLEN-BRADLEY DR
MAYFIELD HEIGHTS OH 44124-9705

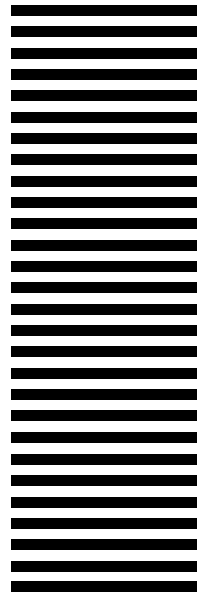

Rockwell Automation Support

Rockwell Automation provides technical information on the web to assist you in using our products. At <http://support.rockwellautomation.com>, you can find technical manuals, a knowledge base of FAQs, technical and application notes, sample code and links to software service packs, and a MySupport feature that you can customize to make the best use of these tools.

For an additional level of technical phone support for installation, configuration and troubleshooting, we offer TechConnect Support programs. For more information, contact your local distributor or Rockwell Automation representative, or visit <http://support.rockwellautomation.com>.

Installation Assistance

If you experience a problem with a hardware module within the first 24 hours of installation, please review the information that's contained in this manual. You can also contact a special Customer Support number for initial help in getting your module up and running:

United States	1.440.646.3223 Monday – Friday, 8am – 5pm EST
Outside United States	Please contact your local Rockwell Automation representative for any technical support issues.

New Product Satisfaction Return

Rockwell tests all of our products to ensure that they are fully operational when shipped from the manufacturing facility. However, if your product is not functioning and needs to be returned:

United States	Contact your distributor. You must provide a Customer Support case number (see phone number above to obtain one) to your distributor in order to complete the return process.
Outside United States	Please contact your local Rockwell Automation representative for return procedure.

www.rockwellautomation.com

Power, Control and Information Solutions Headquarters

Americas: Rockwell Automation, 1201 South Second Street, Milwaukee, WI 53204-2496 USA, Tel: (1) 414.382.2000, Fax: (1) 414.382.4444

Europe/Middle East/Africa: Rockwell Automation, Vorstlaan/Boulevard du Souverain 36, 1170 Brussels, Belgium, Tel: (32) 2 663 0600, Fax: (32) 2 663 0640

Asia Pacific: Rockwell Automation, Level 14, Core F, Cyberport 3, 100 Cyberport Road, Hong Kong, Tel: (852) 2887 4788, Fax: (852) 2508 1846